

THE CETA-RAM BLOCK PRESS

by Roberto Lou Ma, Civil Engineer, Centro de Experimentación en Tecnología Apropiada, Guatemala

1. INTRODUCTION

The CETA-RAM is a manually operated block press, developed by the author just after the February 1976 Guatemalan Earthquake, specifically for the production of hollow soil-cement building blocks. The hollow blocks are intended for use in reinforced masonry for low cost earthquake resistant housing.

The CETA-RAM is a modified version of the well known CINVA-RAM.

The name CETA-RAM honors the Centro Experimental de Tecnología Apropiada (CETA), where it was developed, and the Chilean engineer Raúl Ramírez, creator of the CINVA-RAM.

2. DESCRIPTION

The CETA-RAM is a compact and lightweight machine, mechanically simple, low in cost, and easily operated and maintained. Nevertheless, it is capable of molding at high pressure, dense and neatly finished blocks of high structural quality, at the rate of 300 to 500 units per eight hour shift, when operated by two persons.

Built entirely of steel, it is composed of three main assemblies (see drawings):

- MOULD (1) with COVER PLATE (2)
- PISTON (3)
- YOKE (4) and LEVER DEVICE (5)

The Cover Plate opens and closes the Mold, by pivoting 90 degrees in a horizontal plane. The Piston has two bushings (N) engaging with a sliding fit the two vertical columns (F) fixed to the base of the Mold, and by which means the Piston is vertically guided in its stroke. These cylindrical columns

also function as inserts to form the holes in the blocks. The Lever actuates the Piston to compress the fresh soil-cement mixture inside the Mold, and also to eject the block thus formed. One important feature of the CETA-RAM is that the Piston guiding mechanism never needs adjustment.

3. OPERATION

The making of each block comprises three basic operations:

- Loading the soil-cement mixture into the Mold.
- Actuating the Lever to compress the mixture.
- Actuating the Lever in the opposite direction to eject the finished block.

The block is then manually removed and laid to set and cure moist in a shaded place, for a minimum of seven days.

To ease the handling of the freshly molded blocks, two sheet steel pallets are used: each block is molded with one pallet underneath; after the block is ejected, the other pallet is placed on top of it. The block is then hand carried between both pallets, and carefully laid on its side on the ground, thereby freeing the pallets for immediate reutilization.

Special pallets have been developed, that permit the making of two half blocks per molding cycle.

4. THE CETA-RAM BLOCK

The dimensions of the CETA-RAM block are 32.3 x 15.7 x 11.5 cm. Two 6 cm diameter holes run through its full thickness. The holes simplify the placement of vertical reinforcement in earthquake resistant wall constructions: the steel reinforcing rods running through the holes in the laid blocks, at the required spacing, are set in cement mortar or grout. The length of three blocks, included the respective joints, add exactly one meter. This comes out to be convenient in the planning and execution of low cost housing projects, as it allows a modular coordination on the basis of 50 and 100 centimeters, in both architectural and structural aspects. Twenty four blocks lay up one square meter of wall.

5. EXPERIENCES WITH THE CETA-RAM

The CETA-RAM design has already been fully field proven. To date, CETA has built more than 50 units, used in various rural habitational projects throughout the country and abroad. Some of these machines have produced more than 60,000 blocks apiece, without operational problems and without undue wear. It would appear that with proper care and maintenance, the life span of CETA-RAM, expressed in terms of production, could conservatively be estimated at 100,000 blocks.

Pumitic sandy and silty volcanic soils, very light in weight, abound in our country. Blocks fabricated with mixtures of these soils with cement, in a volumetric proportion of 12 to 1, consistently attain compressive strength values above 35 kg/sq. cm (500 psi).

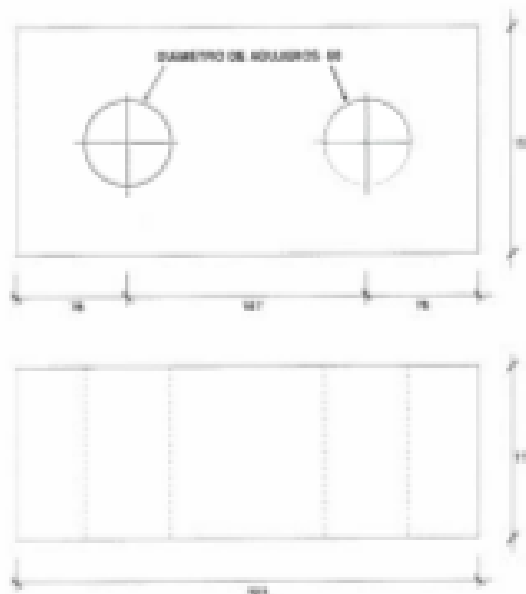

CETA RAM BLOCK

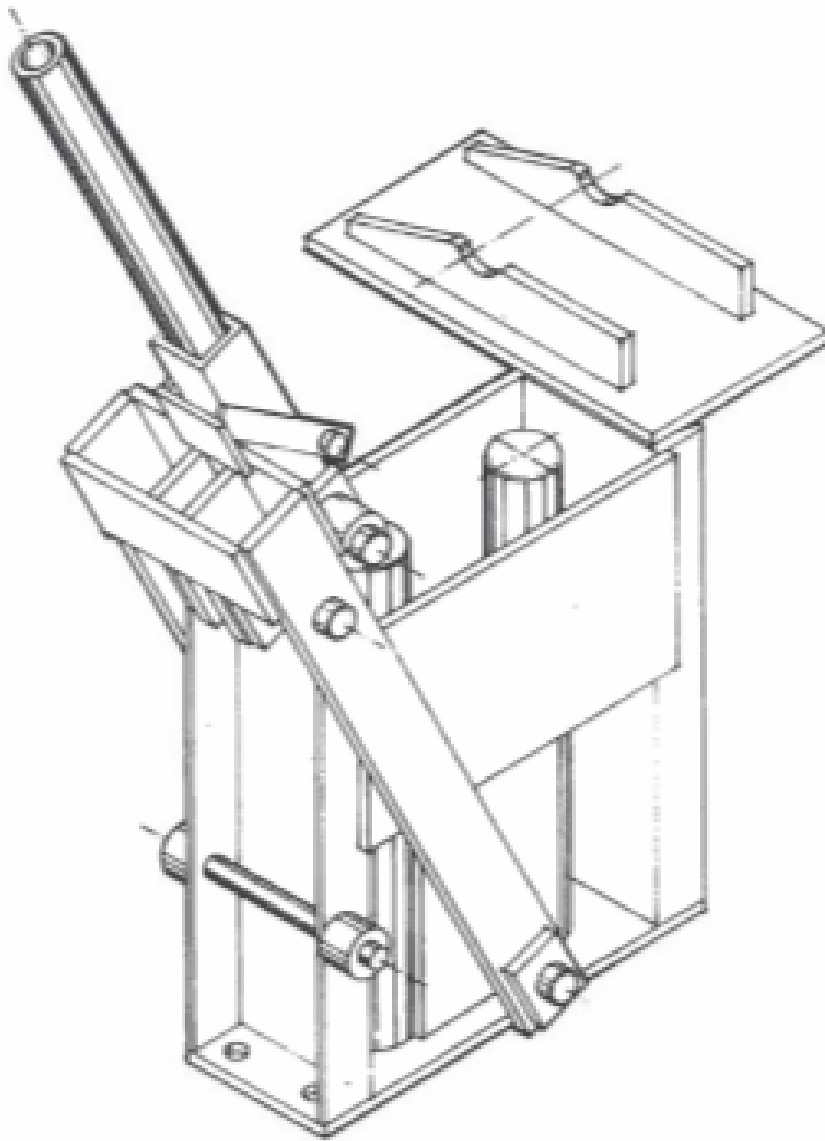

CETA-RAM

DISEÑO Y DIBUJOS DEL INGENIERO ROBERTO LOU MA
CENTRO DE INVESTIGACION EN TECNOLOGIA, ARMENIA

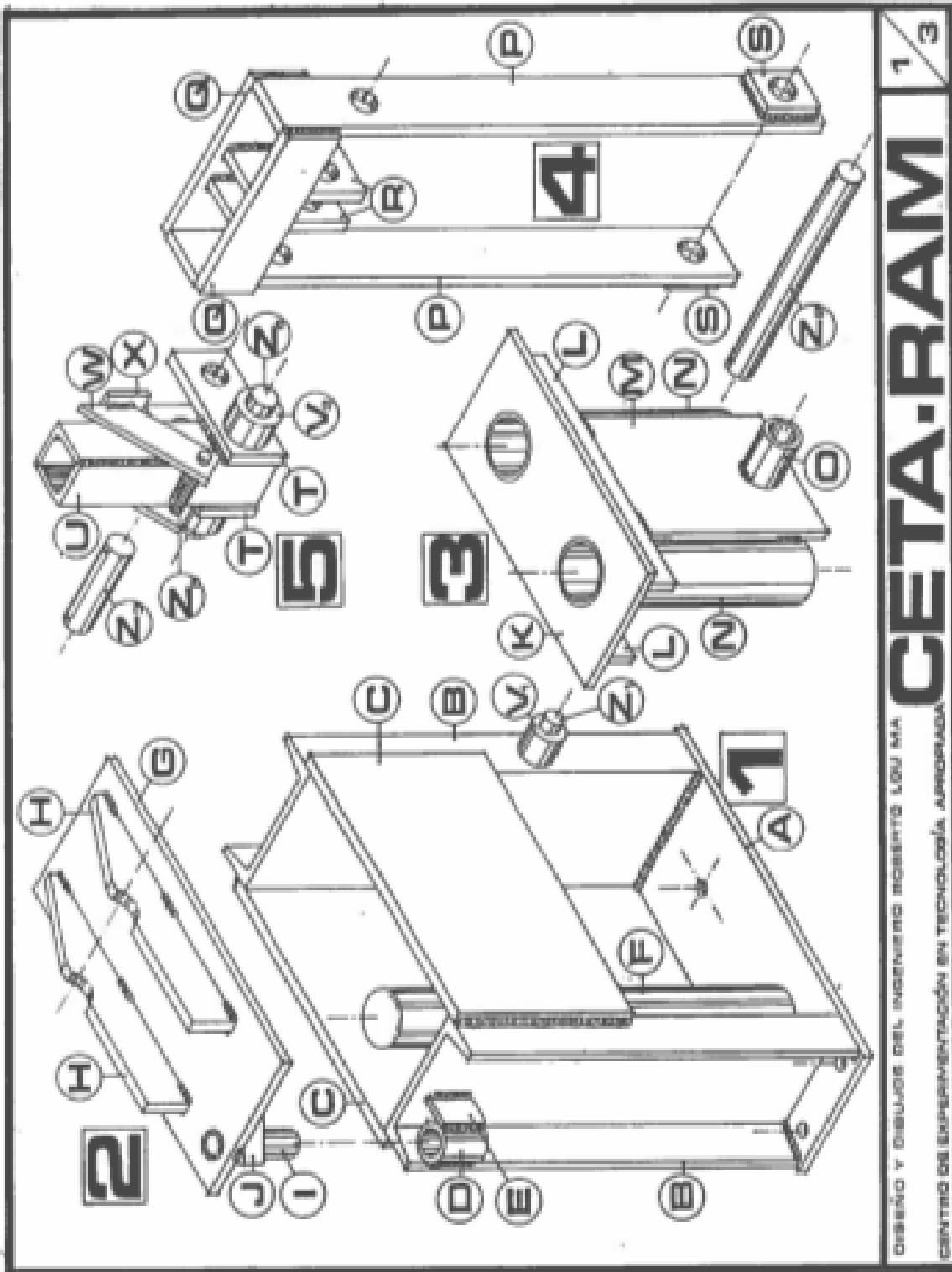

1/3

CETA-RAM

DISEÑO Y DIBUJOS DEL INGENIERO ROBERTO LOU MA.
CENTRO DE EXPERIMENTACIÓN EN TECNOLOGÍA AERONÁUTICA

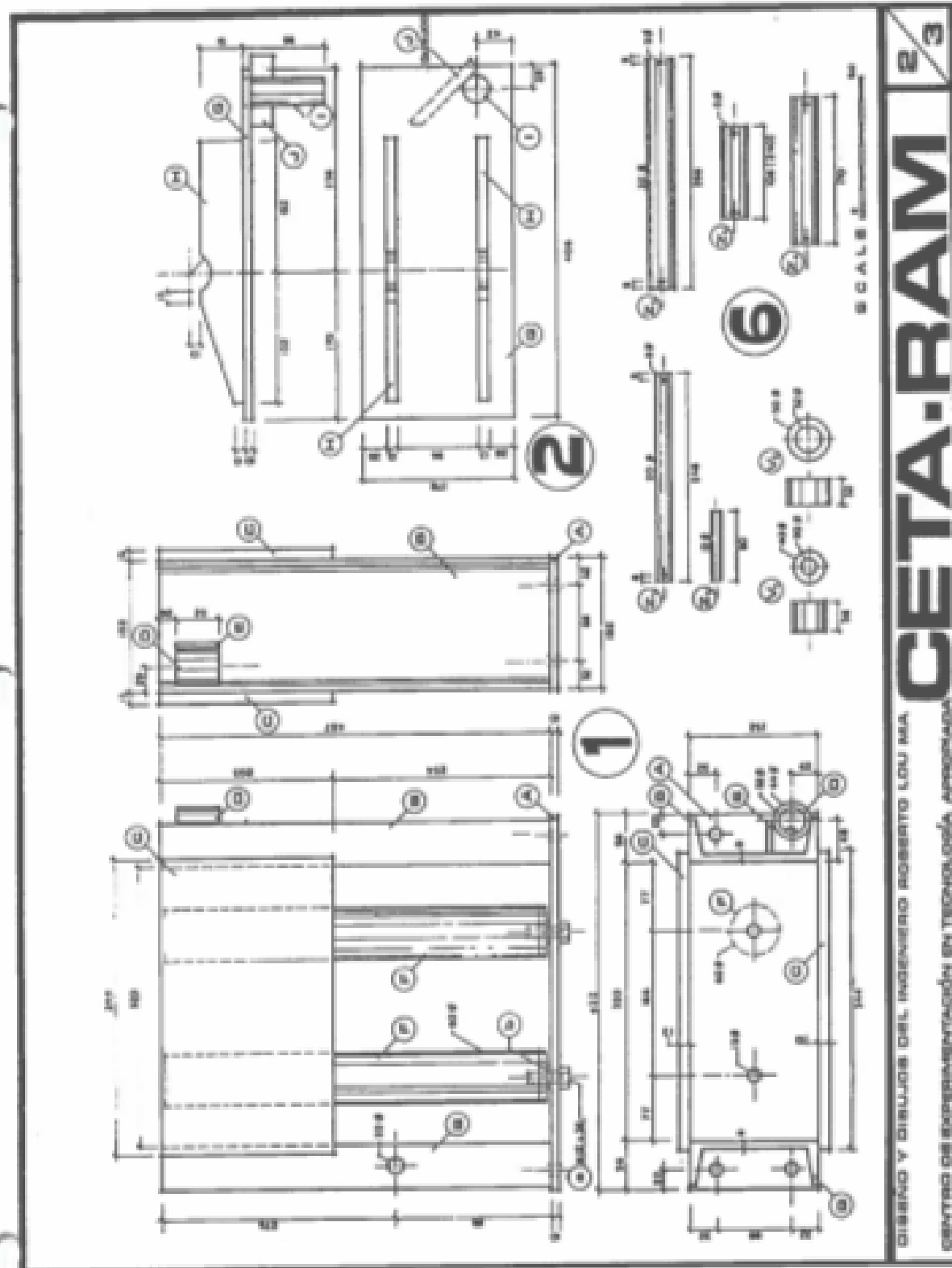

DISEÑO Y DIBUJOS DEL INGENIERO ROBERTO LOU MA.
 CENTRO DE EXPERIMENTACIÓN EN TECNOLOGÍA AERONÁUTICA

CETA-RAM

3

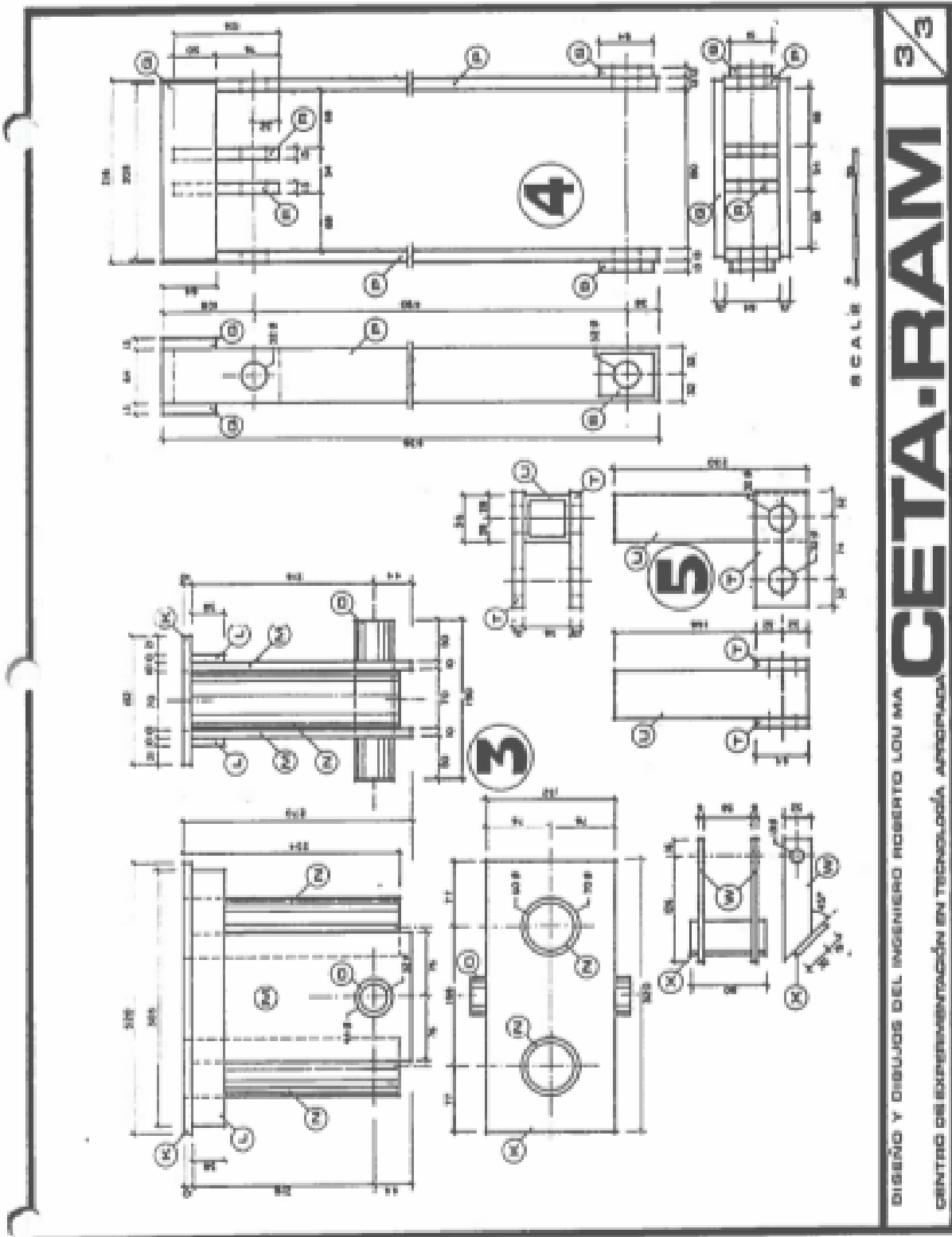





Following, drawings of the CETA RAM with dimensions in inches

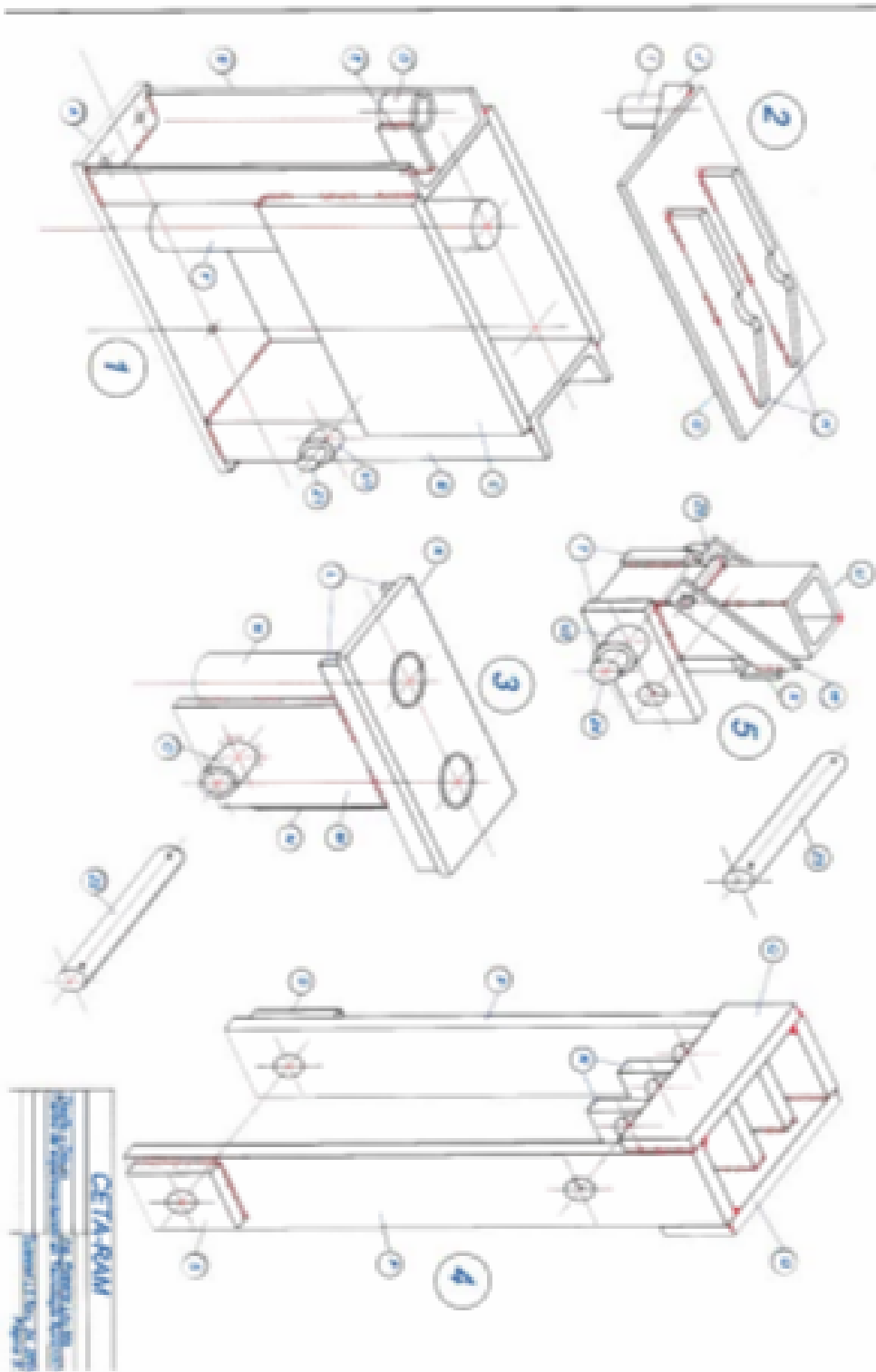

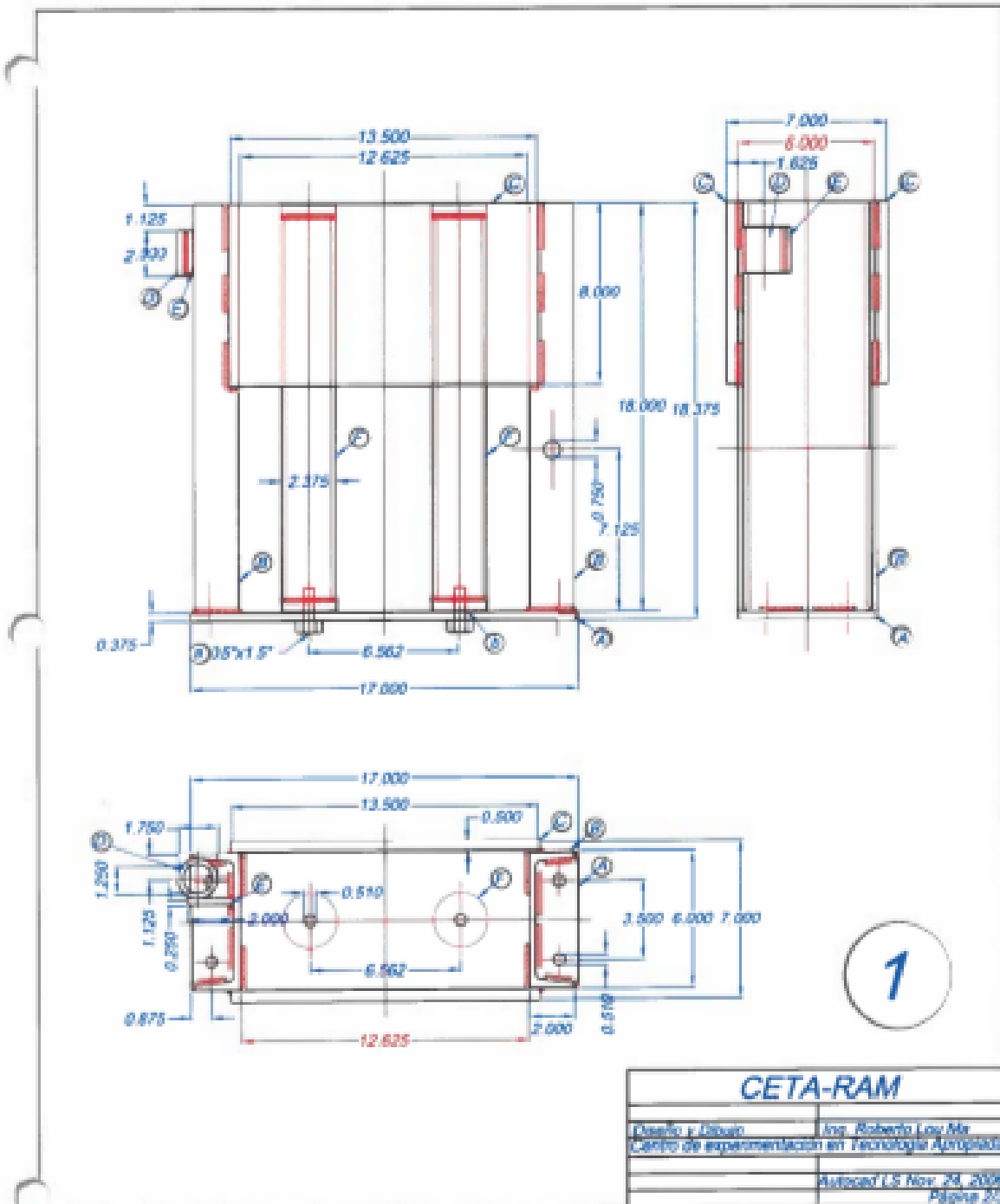

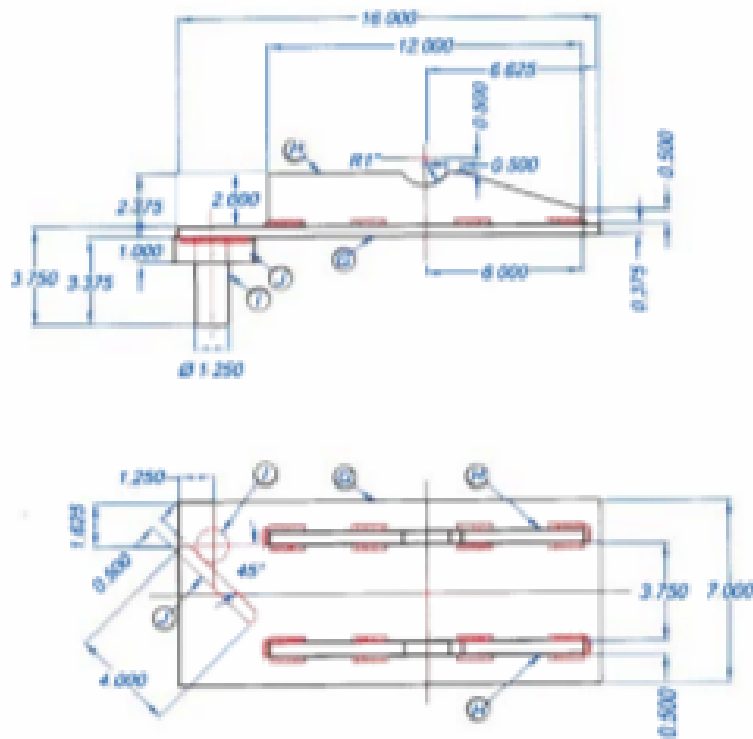

2

CETA-RAM	
Diseño y Dibujo	Ing. Roberto Luis Ma
Centro de experimentación en Tecnología Avanzada	
Autocad LT5 Nov. 24, 2008	
Página 23	

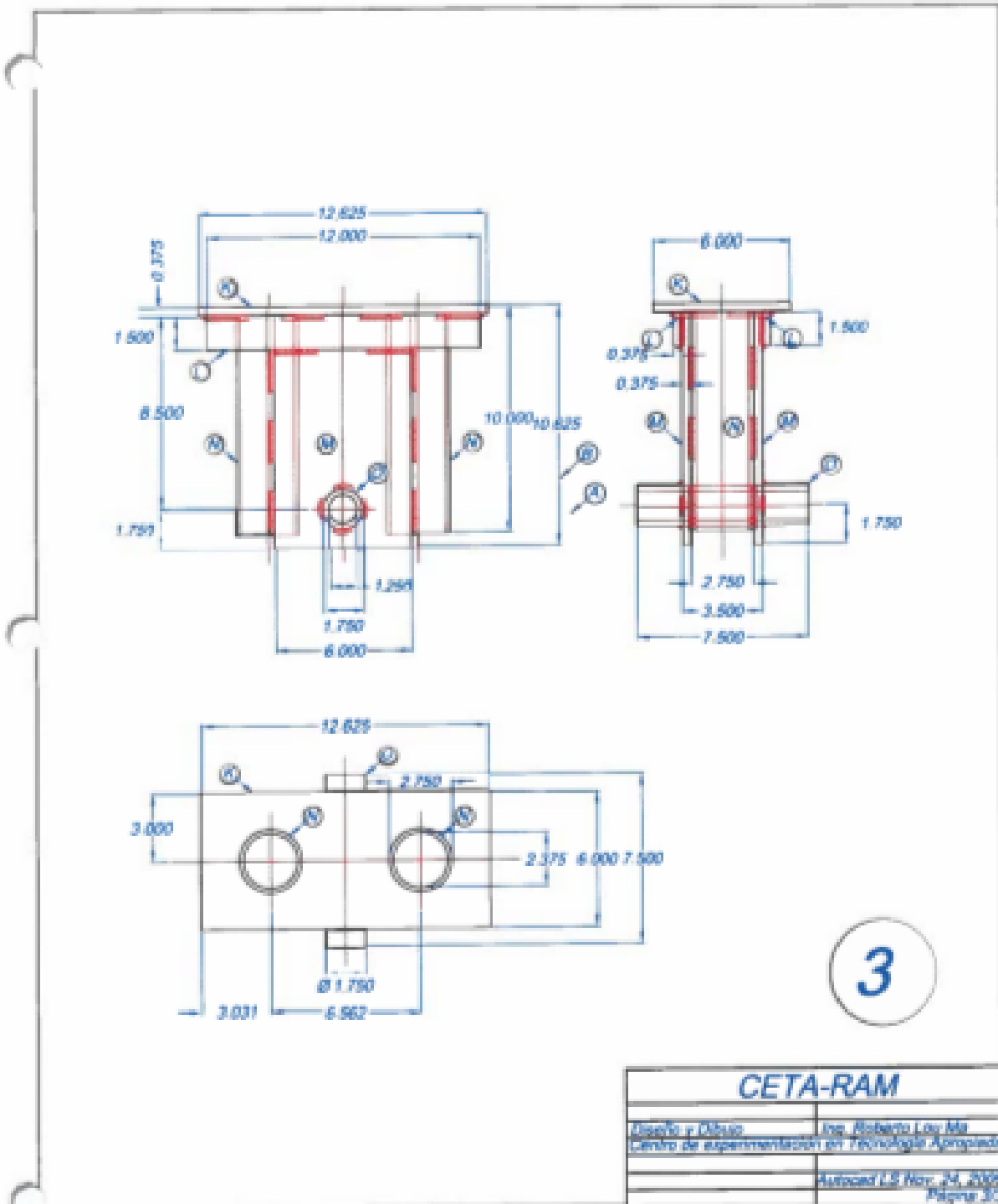

CETA-RAM	
Diseño y Cálculo	Ing. Roberto Ley Ma
Centro de experimentación en Tecnología Aplicada	
Autosud 1.5 Nov. 14, 2008	
Página 3/3	

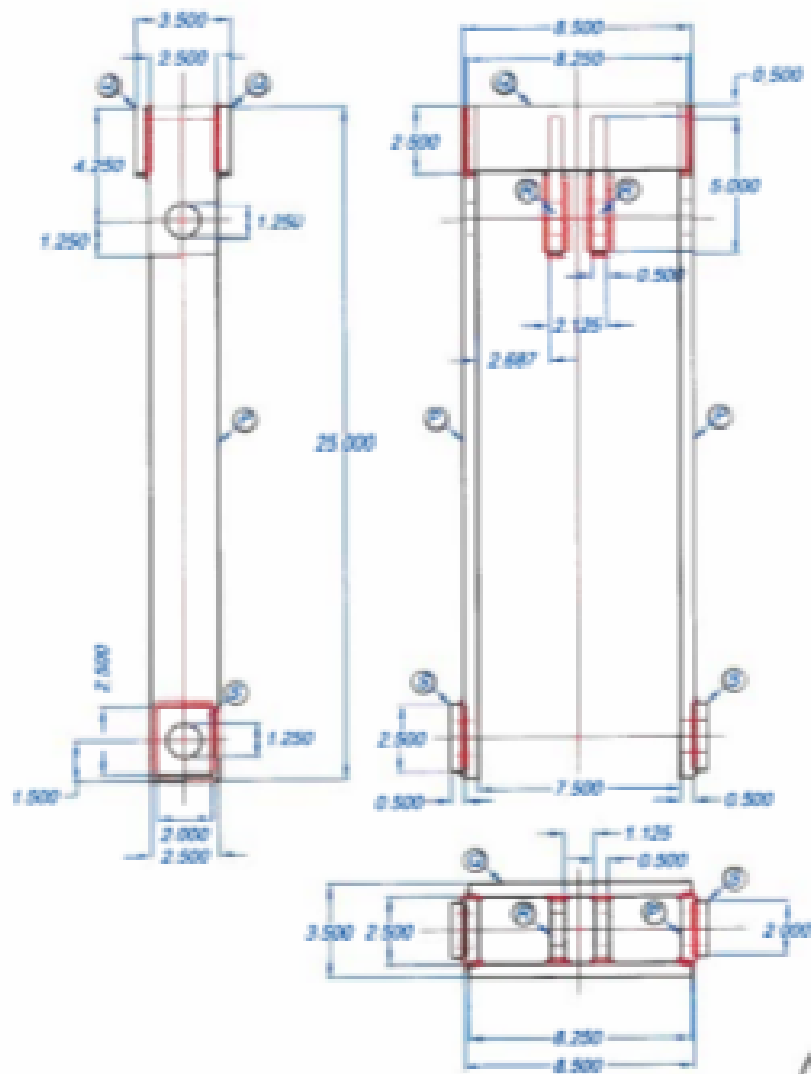

4

CETA-RAM	
Diseño y Dibujo	Ing. Roberto Lora Ma
Centro de Experimentación en Tecnología Aplicada	
Autocad LT 11 Rev. 24, 2008	
Página 32	

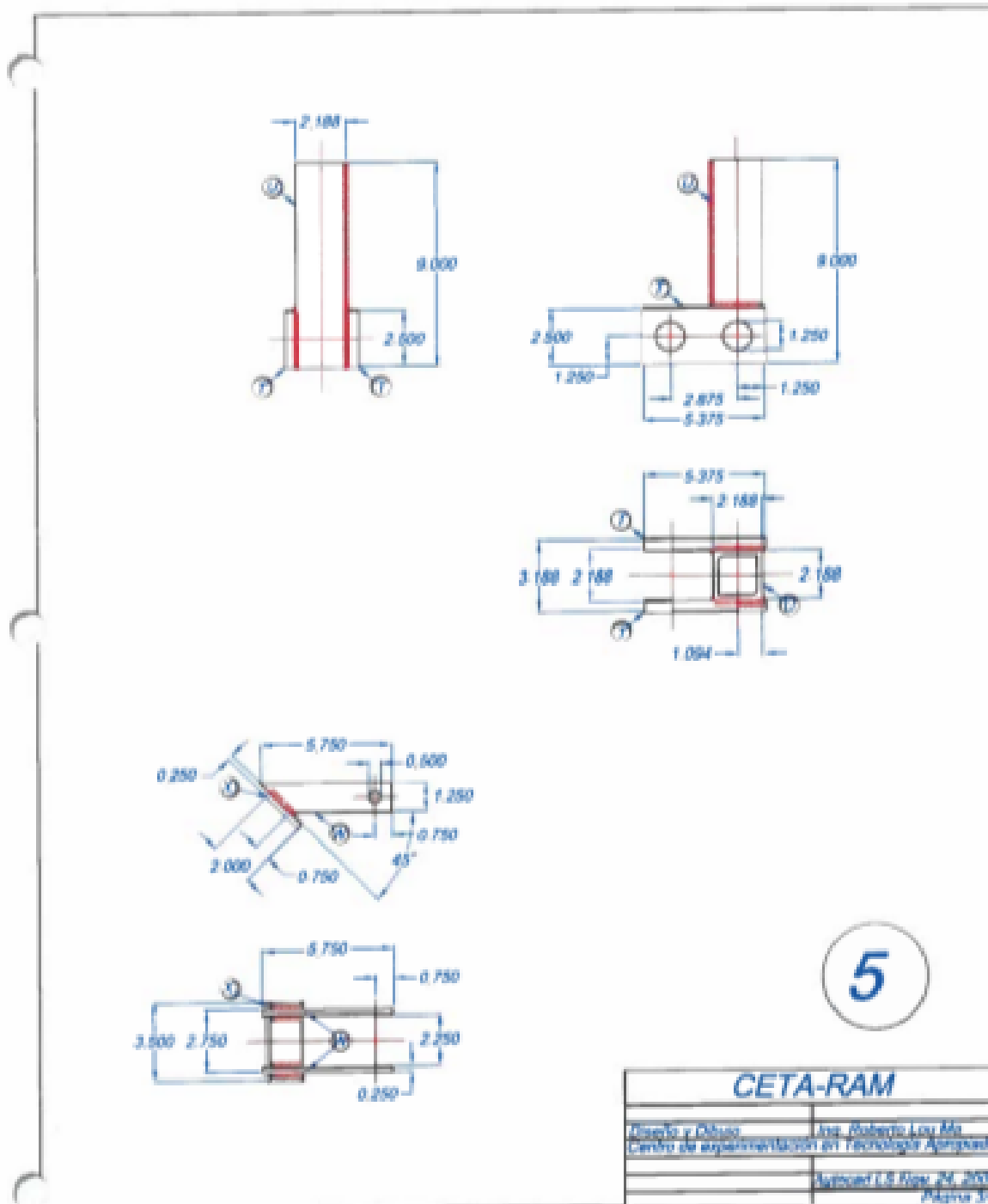

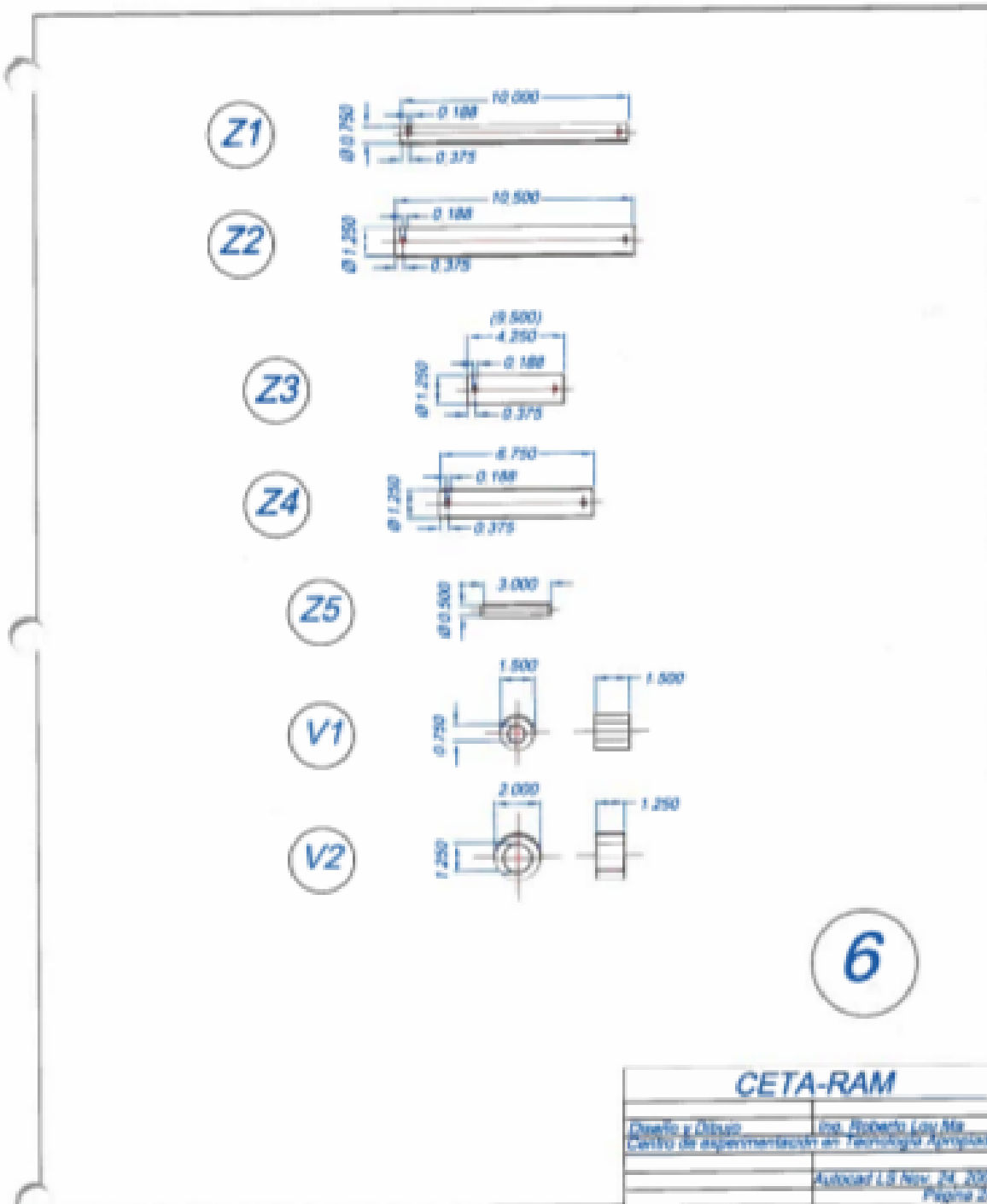

Suitability of Local Soil for Cost Saving Construction Techniques



(with test results of soil samples from Kaski District in Nepal)

Martijn Schildkamp
Architect and Founder of Smart Shelter Foundation
December 2009 (v.2)



Table of Contents

0.	Introduction	1
0.1	Prices of Materials	1
0.2	The Aim of This Manual	2
1.	Soil	3
1.1	Soil Formation	3
1.2	Soil Composition	4
1.3	Soil Structure	6
1.4	Soil Texture	6
1.5	Soil Types	7
1.6	Soil Properties	9
1.7	Soil Summary	10
2.	Lab Testing	11
2.1	Lab Testing Equipment	11
2.4	Lab Testing of Compressibility	12
2.3	Lab Testing of Plasticity	13
2.2	Lab Testing of Particle Size Distribution	14
2.5	Lab Testing Summary	14
3.	Field Testing	15
3.1	Field Testing Equipment	15
3.2	Field Testing of Structure and Texture	17
3.3	Field Testing of Compressibility	19
3.4	Field Testing of Plasticity	21
3.5	Field Testing of Cohesion	23
3.6	Field Testing of Particle Size Distribution	26
3.7	Field Testing of Shrinkage	28
3.8	Field Testing of Finished Products	29
3.9	Field Testing Summary	31
4.	Soil Stabilization	32
4.1	Earth construction Techniques	32
4.2	Objectives of Soil Stabilization	33
4.3	Methods of Soil Stabilization	34
4.4	Improvement of Soils	36
4.5	Stabilization Summary	37
5.	Soil Testing in Kaski District of Nepal	38
5.1	Taking Samples in Kaski District	38
5.2	Test Results of Mountain Area Soils	40
5.3	Test Results of Plain Area Soils	41
5.4	Test Results of City Area Soils	42
5.5	Recommendations for Further Testing	43
6.	Bibliography	45
Appendix 1 Soil Recognition Forms		

 No rights reserved. All text and information of this publication may be used without the written permission of the author, but this manual may not be reproduced commercially.

Exchange the knowledge, share your experiences, give us feedback!



0. Introduction

0.1 Prices of Materials

Recent trends show an explosive increase in the prices of construction materials everywhere in the world, such as sand, cement and steel. In Nepal, one main cause for these price hikes is the lack of electricity, which has cut down the overall production of cement and steel severely. Another important factor is the constant shortage of petrol and diesel, which has a negative effect on the import of raw materials and which causes a vast increase of the transportation costs. In general we see that when the demand is high, and the supply is short, the prices increase rapidly.



Article from the Kathmandu Post, February 2008.

Therefore it becomes more and more important to start looking for cost-reducing construction materials and methods, as an alternative for these expensive and also often polluting materials. We have to start looking at locally available possibilities, to reduce transport costs and to create local income generating possibilities. We have to promote materials which are eco-friendly and not harmful for the direct living environment of the people. We have to think about manually operated production processes, without the use of electricity, gas or petrol. And we have to come up with simple and understandable ways of transferring this technology to the local communities, to ensure durable results.

Soil is such a material! It is widely available almost everywhere in the world. It can be used in many types of earth construction, such as Cob, Rammed Earth or Stabilized Mud Blocks. These are made from a particular mixture of soil, sand or quarry dust, a small percentage of cement, and modest water. It is essential to be aware of the properties of a soil before using it for construction. Key factor is the suitability of the local soil, which has to be examined and tested first. Then if necessary, the modification and mixture of ingredients can be determined according to the local soil texture.

0.2 The Aim of This Manual

The overall aim of this manual is to learn how to identify soil samples through a number of simple tests, which can be carried out by anyone and directly on site or at home. We are definitely not interested in costly and time-consuming laboratory tests followed by lengthy and difficult calculations. Simply because in most cases such labs are just not available, especially not in the remote mountain areas of Nepal, on the Indonesian islands or in the rural areas of Cambodia.

Chapter 1 explains what soil is. It is not really necessary to understand all of the terminology and somewhat detailed information; it merely gives an idea of how soil is formed and what ingredients it can contain. Also it explains what characteristics are important to know for construction with earth. The summary of this chapter sums up the most important facts that are needed for soil identification.

Chapter 2 gives a brief overview of what kinds of laboratory tests exist, to test a number of different soil characteristics. Basically this chapter shows why we should try to avoid these often too advanced technologies.

Chapter 3 is the main chapter. It describes a sequence of simple field tests, which are called 'sensitive' tests. Instead of sophisticated equipment, we use our eyes, our nose and our hands, along with some water. They are divided in basic sensitive tests, and in a number of additional tests. The additional tests may be more elaborate, and not all of them are truly reliable, but they are very helpful in gaining more knowledge about your soil.

Chapter 4 shortly explains what we can do with the results that we have obtained, such as modifying the soil for certain earth construction techniques.

Chapter 5 explains the best results of many soil samples, which were taken in the hill areas around Pokhara and in Kaski District of Nepal and ends with some recommendations for further research.

The annexes show the forms that we use for soil sampling, and a number of test results from soil samples taken at various places in Nepal.

1. Soil

1.1 Soil Formation

The surface that we walk on, the earth's crust, is the solid part of our planet. Earth materials are solid rock, soil, water, vegetation, and the gases of the atmosphere.

There are three types of solid rock in the world, also known as parent rock:

1. **Igneous rock**, such as granite, gneiss and feldspar, is formed by heat and fire. It is basically molten lava that has cooled down.
2. **Sedimentary rock** has been created over millions of years through processes where different types of rock are weathered into particles, which are deposited into shallow layers by rain and wind, and then compressed under extreme pressure. Examples are sandstone and limestone.
3. **Metamorphic rock** is a composite of igneous and sedimentary rock types, which has undergone structural change and fusion due to extreme heat and pressure. Common types are schist and gneiss.

Soil is the product of the slow decomposition of the solid rock. It can be seen as a stage in a long process of deterioration, in which the parent rock is transformed into smaller components. This breakdown of rock is influenced by the weather (sun, rain, freeze), by transportation (rivers, wind, volcanic activity, farming practice), by biological processes and by animal and plant life. Small minerals migrate downward with the rain (leaching) and upward to the surface (evaporation). The continuous vertical movement creates distinct layers in the sections of the earth; the so-called horizons.

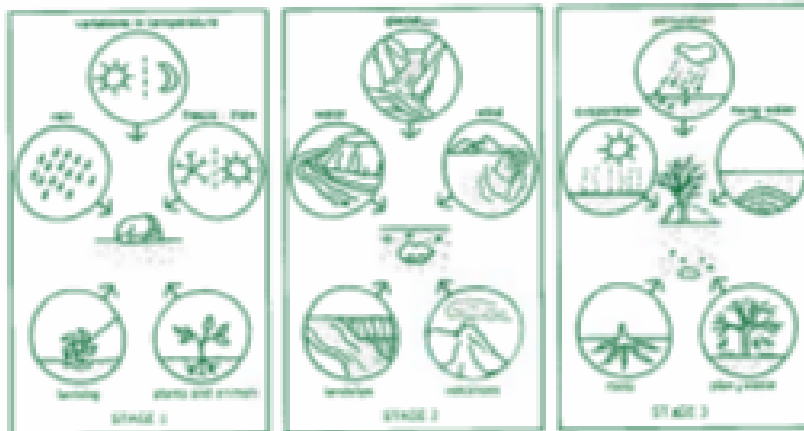

Three stages of decomposition of rock through interaction of different influences.

Soil can be divided into two main groups. There are the young or undeveloped soils, which are shallow and not much different from the underlying parent rock. They are often made up of a single horizon. The others are the developed soils, which are deep, and typified by a succession of leached and enriched horizons. Soil science, or pedology, studies the physical, chemical and biological characteristics of soils in greater detail.

Due to all these different influences, soil appears in an infinity of forms and possesses an endless variety of characteristics.

1.2 Soil Composition

Soil is made up of a number of substances, which can be divided into 4 main groups:

1. Gases form the internal atmosphere of the soil and they fill the voids. They come from the outside air (nitrogen, oxygen, carbon dioxide) or they result from organic decay (hydrogen, methane).
2. The liquids are water or substances dissolved in water. They come from atmospheric conditions (rain, mist, humidity), from mankind, from the weathering of rock and from decay of organic material. They include water, alcohols, bases and acids, salts and sugars.
3. Organic matter is part of the solid ingredients of the soil, but is mentioned separately for its distinct properties. It is usually concentrated in the top layer of the earth. Top soil, agricultural soil and humus should not be used for any type of earth construction!
4. The fourth group is the minerals, also part of the solids and unsolvable in water. They are subdivided into two types, which are the inert minerals and the active particles.

The inert minerals are the coarse grains in the soil, also called granular and referred to as being non-cohesive. They include gravel, coarse sand and fine sand. Too large parts such as boulders and pebbles are often called aggregates. They lie outside the range of sizes which are normally regarded as soil, and are usually removed from the soil mix. Gravel and sand are stable, which means that their properties don't change when made wet.

The active particles are silt and clay, they are referred to as fines and as being cohesive. They are unstable under influence of water, because they can swell and shrink. They act as the binders of the soil, but it has to be clearly said that these factors apply far more for clay than for silt.

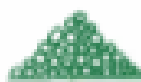

Gravel is made of small grains of rough material, which is the result of disintegration of the parent rock. Their size ranges from 2 to 20mm. Their mechanical properties undergo no detectable change in the presence of water.

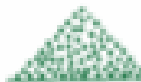

Sand is often made up of small particles of silica or quartz with an open and permeable structure, between 0,075 and 2 mm in size. When compacted, sand particles create a dense soil matrix, but sand will not hold together by itself. A binder is needed.



Silt is basically identical to sand from the physical and chemical point of view. The main difference is the size, which varies between 0,075 and 0,002 mm. It is pulverized rock, sometimes referred to as 'rock flour'.

The powdery particles are round in shape and they cannot be seen by the naked eye. Silt gives stability to the soil by increasing its internal friction and by filling the voids between the grains. They have little cohesion when dry, but when made wet, the films of water between the particles grant a certain degree of cohesion to silty sand.

Too much silt in a soil has a negative effect on the strength and durability of the earth structure. These too small and too round particles don't have the ability to attract sufficient water molecules and the stabilizers cannot encapsulate all the particles in the soil matrix. Too much silt results in gaps in the stabilization process.





Clay is the smallest fraction in the soil, with particles less than 2 microns. It holds the inert grains together and to a great extent provides the cohesion of the soil. Clay is sticky when wet and hard when dry.

Clay particles differ from the other grains in their chemical and physical properties. They are plate-like in shape and are electrically charged, which attracts water molecules like a magnet. The film of absorbed water which adheres strongly to the clay layers, links the micro-particles of the soil together by so-called Van der Waals forces, and gives the clay its high cohesion and most of its mechanical strength.

However, unlike gravel and sand, clay is very unstable and sensitive to variations in humidity. As the moisture content rises, the film of absorbed water becomes thicker and the soil increases in volume. The other way around, the volume shrinks when the soil dries out, resulting in visible cracks. If again the soil structure is exposed to water, the moist can easily penetrate through the cracks and into the heart of the material. This negative characteristic has to be dealt with carefully! Too less clay and the soil won't hold together, but too much clay, and the soil will shrink and crack.

There is a relation between the size, the mass and the surface area of the particles. As the size of the particles becomes less, the number of particles per gram increase and the mass of the individual particles decrease. In reverse, the total surface area of the mass of particles, known as specific surface (in mm²/g) goes up. This explains that the extremely high specific surface of the clay particles is one of the factors responsible for the cohesive properties of clay.. as shown in the figure below:

soil category	particle size	approx. mass of particle (g)	particles per gram (approx.)	approx. surface area (mm ² /g)
coarse sand	1	0.0014	720	2300
fine sand	0.1	1.4×10^{-4}	7.2×10^3	23000
medium silt	0.01	1.4×10^{-5}	7.2×10^4	2.3×10^5
clay	0.001	1.4×10^{-11}	7.2×10^{11}	2.3×10^8

Particle size, mass and surface area of particles with equal spheres (source: Manual of Soil Laboratory Testing).

The coarse grains are referred to as the skeleton of the soil, and the fines act as a binding agent, compared to what cement does in concrete.

Gravels and sands give the material its strength, clays bind it together and the silts fulfil a less clear intermediate function. Together they form a structure which can be called an 'Earth Concrete'. The grains are divided by size according to the following table:

grain size in mm				
pebbles	between	200	and	20 (aggregate)
gravel	between	20	and	2
sand	between	2	and	0.075
silt	between	0.075	and	0.002 (cannot be seen)
clay	smaller than	0.002		(cannot be seen)

The respective proportions and distribution of these ingredients determine the structure and the texture of the soil, which in turn determine the properties of the soil.



1.3 Soil Structure

The particles in a soil are more or less evenly arranged, disturbed or bonded. The way these solid particles are assembled is called the soil structure, which has an effect on the circulation of air and water, and on other physical properties. In general three types of structures are recognized:

Granular structure: The soil is very gravelly and there is very little bonding by clay between the inert particles.

Fragmented structure: The soil is crumbly, coarse particles lump together by some clay bonding.

Continuous structure: Rich mix of all particle sizes; the inert elements are held in a mass of clay and silt.

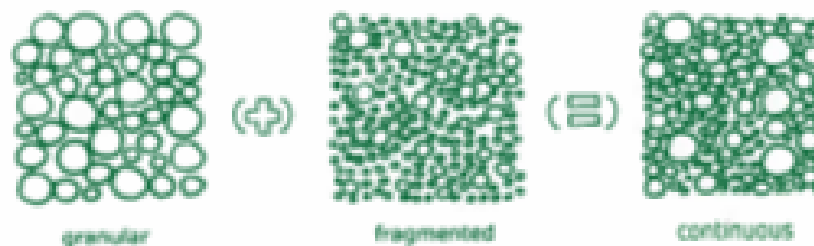

The best structure is the continuous one. As a result of a good distribution of the different grain sizes, the soil has fewer voids and the clay particles can bond sufficiently with the coarse grains. In many cases soils have to be mixed to improve its quality.

1.4 Soil Texture

The texture reflects the distribution of the different grain sizes in the soil and is therefore also known as the particle size distribution, or grading. It is expressed in percentages of the four particle sizes that are present in the soil; gravel, sand, silt and clay. Proportions can vary greatly, resulting in a virtually infinite number of types of soil. Mostly it is the dominant particle fraction of a soil which characterizes its fundamental properties and which dictates its behavior. We recognize 4 main types of soil:

Gravelly soil, in which gravel and pebbles dominate. It has a very rough texture, does not stick and has very limited shrinkage.

Sandy soil, which is gritty, it does not stick and there is almost no shrinkage.

Silty soil, which is a fine soil with low cohesion. It has a silky appearance and a lot of shrinkage takes place.

Clayey soil, an extremely cohesive soil, which is sticky and easy to mould when made wet. It has a significant amount of shrinkage.



SMART SHELTER FOUNDATION

Soil

Nowadays, modern earth techniques such as stabilized soil blocks and rammed earth are being used more and more. For compressed soil blocks the ideal particle size distribution of the soil is 15% gravel, 50% sand, 15% silt and 20% clay. For rammed earth we can generally say that a blend of 70% coarse grains versus 30% of fines is ideal. According to the ideal percentages we can say that a soil is predominantly:

Gravelly when there is more than 15% gravel in the soil
 Sandy when there is more than 50% sand in the soil
 Silty when there is more than 15% silt in the soil
 Clayey when there is more than 20% clay in the soil

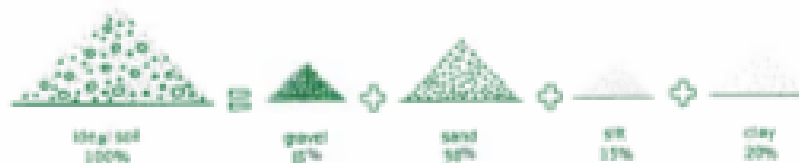

Gravelly (example) 20% 55% 10% 15%
 Gravel and sand are only 5% more, but the sand turns out to be coarse so the overall mix feels gravelly.

Silty (example) 10% 50% 20% 20%
 Because the mixture feels very sticky when made wet, this mix is classified as silty. But the difference between fine sand and silt is very difficult to distinguish!

Unfortunately, many soils are composites which span two or more basic soil types. Therefore, soil always has to be evaluated as a whole, and not as separate components. We must always examine how the various components combine with each other. When another grain size influences the soil to some extent, the classification needs to be more precise. The name of this more specified classification is given to the component which influences the soil the most, and is written down in **bold** letters. The less influencing characteristic is written in normal letters.

Sandy silt is mainly silty soil, with a significant influence of sand
Gravelly clay is mainly clay, with a significant influence of gravel

Sandy clay primary clay fraction with many sand particles
Clayey sand sand with clay influences

1.5 Soil Types

As mentioned above, the four main types of soil are gravelly, sandy, silty and clayey soil, and more specifically combinations of these, with one grain as the predominant grain. But the following soil types are also worth mentioning:

1. Organic soil, such as top soil, humus, agricultural soil, and peat.
 Organic matter is plant and animal remains. It has an open and spongy structure, is often acid and has low mechanical strength. It has a high ability to absorb water, which increases its volume. It is usually dark brown, dark grey, black or blue-black in colour, often with a distinctive smell.



SMART SHELTER FOUNDATION

Soil

Top soil is the layer that contains roots and living vegetation. It is generally 25 to 50 centimeters thick, but the depth of this organic top soil rarely exceeds 1 to 2 meters. Sometimes organic matter can be seen in the form of visible plant components.

Peat is organic matter which is partially decomposed by air, the structure is fibrous and individual leaves, roots and twigs can still be seen. It is often found in former lakes or marshlands.

In other cases the decomposition of the plant or animal structure is so advanced that a black material is encountered. This is called humus, which is more difficult to identify. The soil may be highly plastic, as it generally also contains a lot of clay, but still the cohesion is low. The soil crumbles easily when rolling it into small threads.

It is not recommended to use organic soils for any type of earth construction. Because of the high organic content, ideal or usable soil is rarely found at the surface of the ground, perhaps with the exception of arid soils. On the other hand usable soil is also rarely found at great depths, where there are too many stones, or even parent rock. The depth or height of usable layers of soil can vary greatly, from a few centimeters to several meters.

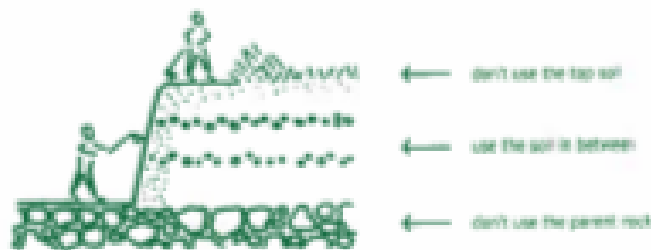

2. Black cotton soil. These are found in wet tropical regions, usually close to weathered volcanic rock such as basalt. The name comes from its very dark colour, ranging from black and deep grey to dark brown, and from the fact that often cotton is grown on it, like in India. The soil is extremely clayey with a high plasticity, swells enormously in wet condition and shows equally severe shrinking upon drying. In the dry state the soil is extremely hard. In india it is also called Regur soil, and in Indonesia it is known as Hargalinic soil. Black cotton soils are categorized as expansive clays and are unsuitable for earth construction.

3. Laterite soils are also found in wet tropical and sub-tropical climates, in high quantities. They can usually be found just below the surface of vast open plains, grasslands and forest clearings, in regions with heavy rainfall. The name derives from the Latin word 'later' which means brick. They are formed through break down of rock by chemical decay in tropical conditions, but signs of their original structure remain present in the soil. They are highly weathered soils which contain large proportions of iron oxide and aluminum. Laterites are rich in iron oxide and are colours range from ochre, red-brown to violet and black, depending on the amount of iron. Typically they harden on exposure by air, and the soil is easy to cut into blocks. The darker the laterite, the harder, denser and more resistant to moisture it is. Bauxites are rich in aluminum and are usually dirty-white.





4. Clayey rock. About 80% of all sedimentary rock falls into this category. They include very plastic clayey mudstones, which can be easily recognized by soaking them in water for a week, after which they can be crushed into clay. Another group is the shales; silico-aluminous rocks better known as schist or slate. They look like rock, are difficult to break down and the granularity of these soils is hard to determine because they don't easily dissolve in water. However, they remain quite crumbly when dry. Examples can be found in the Nepali mountains.

5. Alluvial soils border rivers and streams in the wider valleys. They are rich in minerals and are continuously subject to weathering. Usually the fines, which are the fine sands, silts and clays, are closest to the surface of the ground. The soil texture becomes richer and coarser with depth. The colour may vary from brown ochre in the higher areas, to grey on the plains and black in marshy areas. Alluvial soils are likely to be found in many places in Nepal.

1.6 Soil Properties

The huge variety of different soil compositions, soil structures, soil textures results in numerous soil types, which all have different characteristics. It is often the predominant fraction in a soil which determines the main properties, and the specific mixture of gravel, sand, silt, clay, water and gases lends its specific properties to the soil.

These can be divided into properties of chemical nature, such as the presence of salt, iron oxides, magnesium, calcium, sulfates and carbonates. The other group is the properties of physical nature, which are numerous and include colour, structural stability, adhesion, apparent and specific bulk density, moisture content, porosity, absorption capacity, capillarity, permeability, specific heat, linear shrinkage, dry strength and many more.

Luckily, for earth construction it is not necessary to have an exhaustive knowledge of all these chemical and physical properties. For our purpose it is not so important to determine the hydrous state, the in-situ density and the gaseous or liquid components of the material. It is sufficient to have a clear understanding of the 4 fundamental soil properties, which are:

1. Granularity or texture. This is the grain or particle size distribution, which gives the percentages of gravel, sand, silt and clay in the soil.
2. Compressibility. This is the ability of a soil to be compressed to the maximum and the potential to reduce its porosity to a minimum. It is related to the energy of compaction and to the optimum moisture content. When a force is applied to a quantity of soil, the material is compressed and the size of voids decreases. The more the density of a soil can be increased, the lower its porosity will be and the more difficult it will be for water to penetrate.
3. Plasticity. This refers to the possibility of a soil to be submitted to deformation without elastic failure, which is characterized by cracking or crumbling. It defines the ability of the soil to be moulded.
4. Cohesion. This defines the capacity of the soil grains to remain together when a tensile stress is imposed on the material. The cohesion of a soil depends on the adhesive qualities or cementation properties of the fines, which binds the inert grains together. This property is strongly linked with the plasticity.

In the next chapters we will see how to test a soil for these basic properties.



1.7 Soil Summary

The origin of a soil is largely determined by the nature of the parent rock, the climate, the vegetation and the topography. These different influences result in an infinite number of soil types with endless varieties of characteristics. Not two deposits have the exact same composition and we may assume that a soil sample taken on a specific point is already different from a sample taken a few meters away.



Section of the soil structure near a newly constructed road near Kajari in the Kaski District of Nepal. Many different shades of colours can be easily identified, which indicates many different types of soil.

The best soil structure is the continuous one, with a good distribution of the different grain sizes. The main ingredients of a soil are gravel, sand, silt and clay. An ideal soil for most modern types of earth construction has 15% gravel, 50% sand, 15% silt and 20% clay.

Depending on the distribution of the grains, a soil type can be gravelly, sandy, silty or clayey. In most cases not one, but two grain sizes determine the characteristics of the soil.

The particle size distribution is one of the fundamental soil properties that we are interested in. The others are plasticity, compressibility and cohesion.

For this a variety of soil tests exist, which are described in the next two chapters.

2. Lab Testing

For some purposes, soil has to be tested very detailed and accurately on the microscopic and sometimes even the atomic level. Soil scientists may be interested to learn the influence of montmorillonitic clay particles in a ferralitic soil. Agriculturalist need to have an insight in the quality and quantity of certain nitrates regarding growth of crops. And road builders have to know the optimum humidity levels in the soil mixture.

Laboratory tests are sophisticated and time consuming. The most frequently used lab tests are the determination of the particle size distribution and the optimum moisture content. These are described briefly in this chapter, mainly to show why these are impractical for our purpose. Chapter 3 shows simple alternatives for them.

2.1 Lab Testing Equipment

Accurate testing of soil in a lab follows strict protocols and takes place under highly controlled conditions. For these a range of devices and machines is used, which require specialized handling and have to be calibrated regularly.

Soil sampling of disturbed samples is usually done with manual drilling or mechanized boring equipment. Disturbed soil is accurate enough for the determination of mineralogy and granularity of the soil. However, if an undisturbed section of the earth is needed, an auger is used to create a cylindrical core sample.

The weight of the sample depends on the type of test that will be carried out. For smaller samples an electronic scales is used, with an accuracy of 0.1.

When the samples have to be dried, an electrical oven is used, and the samples are stored in metal containers. The usual requirement for drying soil is between 105 and 110°C, for a period of 12 to 24 hours. The oven must maintain the desired steady temperature during the complete drying period and free circulation of air within the oven is essential. Cohesive soils, tropical soils and soils containing organic matter should not be dried, because the process may alter its properties.



Some examples of sophisticated laboratory testing equipment.

Lab testing of the compressibility of a soil is done with the Proctor test. The plasticity is tested with the Casagrande apparatus or the Cone Penetrometer. The particle size distribution is tested with a large number of sieves for the coarse grains, and a sedimentation test for the fines. These tests are briefly shown in the next few pages.

2.2 Lab Testing of Compressibility

The water content at which the soil has the maximum dry unit weight is called the Optimum Water Content (OMC). This is the amount of water that is needed to achieve the maximum dry unit weight during a given compaction energy.

If the moisture content in a soil is too low, the particles will be insufficiently lubricated and it will not be possible to compact the soil to its minimum volume.

If the moisture content is too high the soil may swell and the pressure of the compacting machine will be lost by the high volume of water trapped between the particles.

The three main variables which affect the maximum dry density are the texture of the material, its hydrous state and the compaction energy used.

The OMC is determined by the Proctor test, which is labor-expensive and time-consuming. A mould with a 4 inch diameter is filled with three equal layers of soil with a fixed moisture content. Each layer is compacted with 25 blows of a 2.5 kg heavy hammer, dropped from a height of 30 centimeter. After filling, the mould is trimmed to the top level and the wet weight of the soil and its moisture content are determined. This procedure has to be repeated for several increasing moisture contents, until the highest possible density is reached.

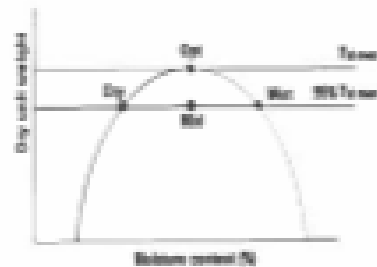

Equipment for the Proctor test, resulting in a diagram of the OMC versus the dry unit weight.

A compression test that can be conducted on finished products, such as stabilized mud blocks, is done with a compression machine. These can be found at most technical schools and engineering colleges. First make some test blocks, which have to be cured for 7 days and then must be soaked in water for 48 hours. The frogs in the block have to be filled with a cement mortar. The compression after 9 days resembles 70% of the strength of a 3-week-old block. Then compress the block in the compression machine. Ask the operator for the calibration factor, which generally is around 90%. This means, that a block can handle slightly less than the machine tells you. With these factors calculate the strength of the block after 3 weeks.



Testing the strength of blocks with the compressing machine.

2.3 Lab Testing of Plasticity

The moisture content of a soil is one of the characteristics that is most frequently determined. When a soil is made wet, it can have various states of consistency: liquid, plastic or solid. If lots of water is added, the soil behaves fluid, known as the liquid state. If the moisture content is gradually reduced by drying, the clay particles begin to hold on together and start resisting deformation. This is the plastic state.

The boundaries of these states are collectively known as the Atterberg limits, of which the two most important ones are the Liquid Limit and the Plastic Limit. The transition from the fluid to the plastic state is called the liquid limit. When the soil stops being plastic and becomes solid and brittle, the plastic limit has been reached. The combination of the liquid limit and the plastic limit specifies the sensitivity of the soil to variations in humidity.

The liquid limit can either be tested with the Casagrande Apparatus or with the Cone Penetrometer. These measurements have to be carried out on the fines of the soil, the so-called mortar of the soil, which are fine sand, silt and clay. Therefore the samples are first sieved with a 0.425 mm sieve.

When using the Casagrande apparatus, the base of the cup is filled with soil and a groove is made in the middle. The metal cup needs to be raised in steps of 10mm and then dropped freely. The liquid limit is the moisture content of a soil when 25 blows cause 13mm of closure of the groove at the base of the cup.

The cone penetrometer is considered a more satisfactory method, because it is a static test which relies on the shear strength of the soil, rather than on dynamic influences. Here the liquid limit is represented by the moisture content, at which a steel cone of 80 grams sinks exactly 20 mm into a cup of remoulded soil. At this moisture content the soil will be very soft.



The Casagrande Apparatus.

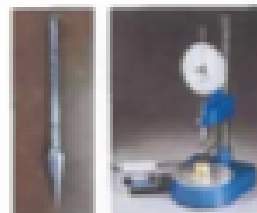

Cone Penetrometer Device.

The plastic limit test determines the lowest moisture content at which the soil is plastic. Needed for this test are an unscratched glass plate, a glass roller device, a steel rod of 3mm thickness to compare your result and an apparatus for the moisture content determination.

A sample of 20 grams must be kneaded into a plastic ball, which has to be re-molded and rolled between the glass plates. The plastic limit is reached until the point that longitudinal and transverse cracks appear, at a rolled diameter of 3 mm. At this point the soil has a stiff consistency. The threads have to be put in a container, weighed and oven-dried, before determining the moisture content.



3.4 Lab Testing of Particle Size Distribution

To determine the grain size distribution of a soil sample, two separate and quite different procedures are used. These are the sieving test and the sedimentation test.

The sieve test is carried out on the coarse particles, which are gravel and sand. First the sample has to be prepared, by washing out the fines which are silt and clay. This is done by wet sieving with a 75 micron sieve. Then the sample is air dried and guided through a series of in between 7 to 19 metal sieves, ranging from 4 to 0,075 mm. The process of separation is mechanically aided by a sieve shaker device. After this the proportions can be measured by percentage of weight.



A sieve shaker set.

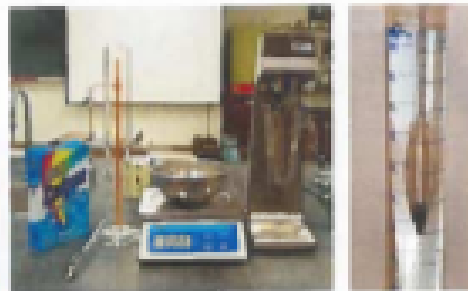

Equipment needed for the sedimentation test.

On the smaller particles; the silts and clays, a sedimentation test is performed. With a hydrometer the density of soil suspension is measured, according to the different speeds at which the particles settle.

First the fines have to be separated from sand and gravel by the wet sieving method. They are deposited in a 500 milliliter graduated glass cylinder, filled with pure distilled water. To make sure that all particles are separated from each other, a dispersing agent is added to the mix. The most common is sodium hexametaphosphate, which can be compared with standard automatic dishwasher detergent.

Variations in density are measured at regular intervals, at a given height, ongoing with actual temperature. The speed at which the particles settle depending on their size enables one to calculate the proportions of the various sizes of particles. An extensive example of the procedures and calculations can be downloaded from www.globe.gov.

3.5 Lab Testing Summary

An elaborate range of laboratory equipment for soil testing is available. Since many of these tests require electricity, they are unsuitable for a country such as Nepal, where people have to deal with a 16 hour daily power cut. During the year 2009 this was the case for many months and the prognosis is that this situation will remain for many years to come. Other reasons are the unavailability of the required materials. It will be difficult, if not impossible, to find the necessary machines, sieves, hydrometers, solution agents etcetera in most developing countries, especially in the remote areas.

Luckily we can do without all this equipment, as the next chapter will show.

3. Field Testing

This chapter shows a sequence of simple field tests, which can replace the unnecessary, expensive and time-consuming lab tests as briefly described in the previous chapter. Generally they follow the guidelines as lectured at the Earth Institute in Auroville, Tamil Nadu in the South of India, which can all be carried out directly on site. These are called the **basic sensitive tests**.

The only drawback is that some of the tests require a lot of practice and experience to interpret them correctly. Especially the difference between clay and silt may be difficult to determine in the beginning. Therefore a number of additional tests are also included here. Some of these require a bit more time and are best carried out at home. Still, they are simple and will give further insight and understanding of your soil characteristics. They are marked as **additional tests** in this manual.

It is important to understand that all these tests, and especially the additional ones, give merely an indication of the soil properties, rather than a fully conclusive outcome. We must accept a certain level of tolerance, but when the tests are carried out systematically and with care, it is possible to make a fairly accurate estimation of the soil quality. Then, after modification of the soil, with or without stabilizers, we only know the real mechanical performance of the building material by making some test blocks. A few tests for this purpose have been included at the end of this chapter.

3.1 Field Testing Equipment

The basic tests rely on the human senses and are therefore also known as sensitive tests. The only tools for the basic field tests are your hands, eyes, nose and mouth, some water and flexa, and a blunt knife, for example made of a saw blade.



Some simple household products is all that is needed for the basic field tests.

For digging out samples a simple spade can be used. Always first remove all organic soil and start digging at about 1 or 2 feet deeper than the top soil level. The hole should be well oriented towards the sun, which makes it easier for observation. Samples should be taken from homogenous layers and it is important that the samples are representative for the whole site. This in itself can prove to be quite a difficult task. As mentioned earlier, the soil consistency can vary considerably, so first do a visual check of the consistency and variations over longer stretches.

Different soils should not be mixed together, and rather than trying to create an "average" soil it is recommended to take at least 3 samples per site.

SMART SHELTER
FOUNDATION
Field Testing

The sample size and weight will depend on the number of tests to be carried out. In principle 1 to 2 kg is more than enough for field testing; if the soil is coarse you need a bigger sample than when the soil contains more fines. If you want to make test blocks, you need about 10 kg for each block.

Label your samples with an identification card, on which you write data such as place and date of collection, depth of excavation, colour of the sample, sequence number when more samples are taken from one site, and any other particularities of the location.

In case some additional tests have to be carried out at home, a well-lit bench with sufficient working area is recommended, preferably exposed to northern daylight. Direct sunlight should be avoided, as well as artificial light, as this will cause distortion of the colour of the soil. The work space should be close to a water tap and the sink should have a silt trap.

In case the soil sample has to be dried, simply burn it over a hot fire in a steel pan. Stir the contents until after 10 to 15 minutes dust particles start flying away from the pan. At this point the soil is sufficiently dried for our testing purposes. Weighing of the samples, if necessary, can be done with a simple kitchen scales.



Use a steel pan on a hot flame and simple kitchen scales to prepare your samples.

One last note: It may be very useful to inquire with the people living in the area. They may be able to supply conclusive information, particularly if earth is being used for building in the locality, which suggests that there are usable deposits.

3.2 Field Testing of Structure and Texture

The first basic tests make use of our eyes by studying the structure and colour, and our hands by feeling the samples. Then we use our nose for smelling and our mouth for tasting the soil. These checks are perhaps 20% accurate, but they give a rough and first general idea of the structure and texture of the samples. Some of these tests are not meant to approve of a type of soil, but rather to reject it, such as organic soils.

Further tests on the texture and granularity are described at the 'Field tests for particle size distribution' further on.



Basic Test 1: Visual test.

Duration: few minutes

Spread out a thin layer of some dry soil on a flat surface. The soil is examined with the naked eye to estimate the relative proportions of the coarse particles and the fines. The variety in grain sizes, especially gravels and sand, can easily be seen. Remove stones and large gravel, sticks, leaves and other foreign matter. Interpret and note down whether the soil is granular (gravelly), fragmented (sandy) or continuous (lots of fines).

Also take a look at the colour. Although it is not very reliable, because the colour varies with moisture content, it may provide some information. Red and dark-brown may come from iron in the soil. Soils with a lot of coral, lime or gypsum may be white, yellow or some shade of gray. More importantly, olive-green and light-brown ranging to black colours may indicate organic soils. Note down the colour.



Basic Test 2: Touch test.

Duration: few minutes

After removing the largest grains and other unwanted ingredients, now also remove as much gravel as you can. Crumble the soil between the tips of the fingers and the palm of the hand. If it feels very sharp and gritty, it means that there is a lot of sand. If it is smooth and powdery, like white flour or talcum powder, there are a lot of fines present.

Now take some lumps, if any, and crush them between your fingers. When they crush fairly easy and powdery, it may be an indicator for silt. When they are very hard and difficult to crush, they contain a lot of clay. This can be emphasized by moistening your fingers and slightly wet the lumps. Clay lumps immediately become plastic and sticky.

A second test that can be done on the lumps, is to scratch them with your thumbnail. If a fine soft powder comes of, the soil is high in silt or clay. Then wet the surface of your thumbnail and polish the lump. If a nice shine appears the soil is rich in clay. Note down whether the texture of the soil is coarse, medium, fine, or fine with lumps.



Basic Test 3: Smell test.

Duration: few minutes

Immediately after taking the sample, smell the soil. Add a few drops of water to enhance the odour of the sample. If the soil smells damp and musty or even rotten, it contains a lot of organic matter. This smell comes from decaying plant and animal matter and will further increase when the sample is heated. If organic matter is present, the soil is unsuitable for our purpose and further testing is not necessary. Note down whether the smell is rotten, musty or agreeable.

**Basic Test 4: Taste test.**

Duration: few minutes

Take a pinch of soil and crush it lightly between the teeth. There is no risk involved here, as soils are usually quite clean. The sharp and hard sand particles will grate between the teeth in an objectionable way; even fine sands will do this. Silt will create a slightly grating sensation, but not in a way that it feels disagreeable; it feels more smooth than sand. The clay grains are not gritty at all and feel very smooth and powdery.

Then take some small dry lumps and try to stick them to your tongue. Silt lumps are likely to fall down, but clayey lumps will stick to the tongue.

Interpretation of test 1 to 4:

A gravelly soil contains many large and hard particles and is very rough
A sandy soil contains many coarse to small particles and feels rough
A silty soil is thin and soft and has small, powdery lumps
A clayey soil is very thin and has big and hard lumps

Soils containing organic matter should not be used and there is no use for further testing.

**Additional Test 1: Ball Drying test.**

Duration: one hour

This can be done when you have an overall feeling that your sample is gravelly or sandy. Take a handful of the entire soil, as excavated on location. Add some water to it, enough to mould a slightly moistened ball in your hand. It should have just enough water in order to keep the particles together.

Then place it into the sun to dry. If it quickly falls apart during this drying period, the sample indeed contains more gravel and sand, compared to silt and clay. Note down the result.

3.3 Field Testing of Compressibility

Some tests to determine the compression characteristic of the soil, the strength and the optimum water content, as well as the presence of clay. Only the hands and some water are needed.



Basic Test 5: Compression test.

Duration: few minutes

Take a small hand of soil, add not too many drops of water and press a ball in your hand in about 5 times. This tells you about the amount of pressure that you have to apply, and also about the cohesion. Note down whether the compressibility is low (gravel), medium or high (clay).

A gravelly soil requires a lot of strength to press, but can be done with very short pressure
 A sandy soil requires some strength to press, which can be done with short pressure
 A silty soil requires little strength to press, but a medium pressure is needed
 A clayey soil needs very little strength, but a long pressure is needed



Basic Test 6: Drop test.

Duration: few minutes

This test is done with a full sample containing all ingredients, but without stabilizer. However, the same test applies for testing the optimum moisture content of your modified mixture, just before pressing the blocks.

Take a hand of soil and wet it just enough to make a cohesive ball, which does not stick to the fingers. Drop it from shoulder height on a hard surface. Note down the result.

If the ball stays in one piece, there is either a lot of clay in it, or the ball was too wet.
 If the ball breaks in 4 to 6 bigger pieces, it indicates a continuous, well-graded soil
 If the soil breaks into many pieces, the sample either contains much sand, or insufficient water was added.



too much clay
or too wet

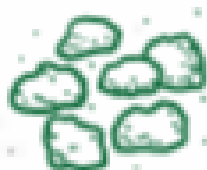

suitable for use

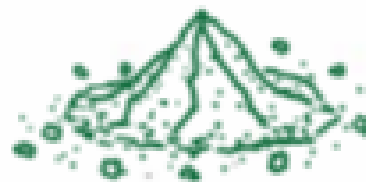

too much sand
or too dry



Additional Test 2: Crumbling test.

Duration: 1 day

The next two tests are also called dry strength tests, and aim to determine the presence of clay in the soil. Both are carried out on the fines of the soil, so first sieve the sample with a 425 micron sieve.

Add enough water to mix it into a plastic state, which means that the soil is rather soft, but still strong enough to maintain its shape. Make some balls, a few of 25 mm diameter and a few of 6 mm diameter. Allow them to dry completely, which may take a half up to a full day, depending on the sun. When dry, grab them between thumb and index finger, and try to crush them. Note down if the dry strength is low, medium or high.

When both sizes break easily, it indicates a low dry strength, and the clay content is probably less than 10%.

When only the smaller sized balls break, the dry strength is medium and the clay content will be between 10 and 20%.

When neither of the ball sizes break, the dry strength is high, with clay content greater than 20%.



Additional Test 3: Biscuit test.

Duration: 1 day

Similar to the crumbling test, but instead of balls we make pats or disc shaped samples. Also, this test gives an indication of shrinkage.

Use the fine fractions of the soil and mix with some water to a plastic state. Use a ring of 3 centimeter diameter and 1 centimeter high as a mould, so that shrinkage can be seen. If not available, just shape some pats by hand. Allow them to dry completely. Then break the biscuits in two halves, and try to powder the halves between your thumb and forefinger. Note down if the dry strength is low, medium or high.

When the disc pulverizes easily and is simply reduced to powder, the dry strength is low and the sample has a high (fine) sand or silt content, but low clay content.

When the disc is not too difficult to break, and can be crushed between the fingers after a little effort, the dry strength is medium and the sample is a good silty or sandy clay.

When the disc is very difficult to break, and breaks with an audible snap, it has a high dry strength and contains a lot of clay. Other indicators are that the biscuit has cracked in the mould, and there is a clear gap between biscuit and mould, due to shrinkage.

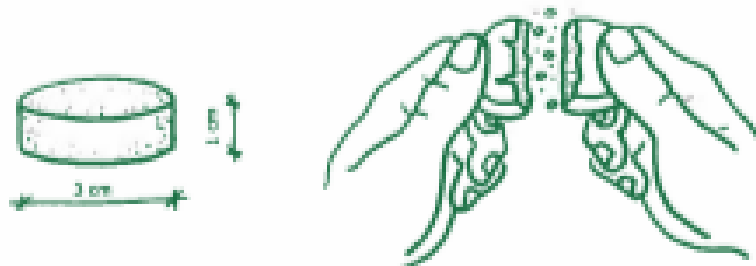

3.4 Field Testing of Plasticity

The basic tests are very easy to do and require not much more than the hands, some water and a blunt knife. The additional tests take much more time and some extra equipment is needed, therefore it is advised to do these tests at home, instead of in the field. Note that most of these tests give information about plasticity and cohesion as well.



Basic Test 7: Shape test.

Duration: few minutes

Add enough water to mould some soil into a cohesive ball, which not sticks to the hands. Note down whether the plasticity is low (gravel), medium or high (clay).

A gravelly soil is very difficult to shape
 A sandy soil is difficult to shape
 A silty soil is quite easy to shape
 A clayey soil is very easy to shape



Basic Test 8: Elasticity test.

Duration: few minutes

Don't add water to the cohesive sample and again shape the ball. Pull the ball into two parts like an elastic band. This also tells you about the cohesion. Note down whether the elasticity is low (gravel), medium or high (clay).

A gravelly soil breaks apart very easily and is not elastic at all
 A sandy soil breaks apart easily and is a little bit elastic
 A silty soil breaks apart after some length and acts elastic
 A clayey soil breaks apart after a long pull and is very elastic



Basic Test 9: Adhesion test.

Duration: few minutes

Soil no water added to the cohesive soil, and again shape a ball. Stick a knife blade into the cohesive ball, pull it out and examine how much the soil sticks on it. Note down if the adhesion is low (gravel), medium or high (clay).

A gravelly soil is very easy to penetrate, does not stain the knife and crumbles the ball
 A sandy soil is easy to penetrate and the knife stays almost clean
 A silty soil is more difficult to penetrate and stains the knife easily
 A clayey soil is difficult to penetrate and stains the blade a lot



Basic Test 10: Shine test.

Duration: few minutes

Also known as the lustre test. Again no water is added to the cohesive ball. Re-shape it and cut it with a knife in two halves. Study the surface of the halves. In addition, you can rub the surface of either a dry or moist sample with your fingernail or with the side of the knife. Note down if the surface is dull (silt) or shiny (clay).

A gravelly soil has a very rough surface with many voids
 A sandy soil has a rough surface with some voids
 A silty soil has a smooth, but dull surface
 A clayey soil has a smooth, but shiny surface



Additional Test 4: Consistency test.

Duration: 15 minutes

Also known as the thread test. Needed is some water and a flat surface. The test is performed on the fines of the soil, so first sieve it with a 425 micron sieve.

Mix a very small portion of soil with sufficient water to make a ball the size of an olive, which is easily shaped, but does not stick to the fingers. Roll it out on a clean and flat surface, forming a thread.

If you can easily roll a thread of less than 3 mm in diameter, the soil probably contains too much clay to be suitable for block making.

If you cannot make a thread at all, and the soil crumbles at any moisture content, the soil may not contain any clay at all.

If it breaks before the diameter of the thread is 3 mm, the soil is too dry; add a little bit more water, make a new olive and do it again. Continue this process until the soil breaks and crumbles at 3 millimeter thickness, which indicates the correct moisture content.

Now take this thread, remould it into a small ball, and squeeze it between thumb and index finger. Note down how much pressure you have to apply and what type of thread is formed:

Weak and fragile thread: It is not possible to make a ball from the thread, without breaking or crumbling it. This indicates a higher (fine) sand or silt content, and very little clay.

Medium-strength thread: The soil can be remoulded into a ball, but when it is squeezed, it cracks and it will easily crumble. The soil has a low clay content.

Tough and hard thread: If the remoulded ball can only be formed with a lot of pressure and it does not crack or crumble, the soil contains a lot of clay.

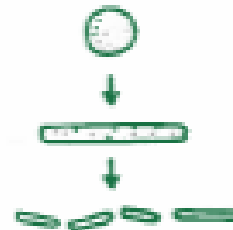
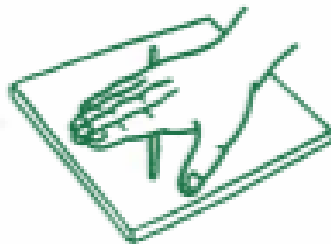

3.5 Field Testing of Cohesion

The cohesion tests will give additional information about the presence of silt or clay in the sample. Nothing more than the hands and some water is needed.



Basic Test 11: Absorption test.

Duration: few minutes

Use the same soil that you used to determine the plasticity, and still do not add any more water to it. Again shape a ball and place it in the palm of your hand. Push a hole in the middle of the ball and slowly pour some water in it. Examine the speed of absorption and note down whether the cohesion is low (gravel), medium, or high (clay).

- In a gravelly soil the water disappears very quickly
- In a sandy soil the water disappears quickly
- In a silty soil the water disappears slowly, after 3 to 4 minutes it will crack the sides.
- In a clayey soil the water stays for a long time



Basic Test 12: Sticking test.

Duration: few minutes

Now make the ball quite wet, squeeze the content a few times firmly and turn your hand.

- If it sticks to the hand, the sample contains a lot of silt.
- If it creates oily water but falls off, it is clay.
- An additional test is to put this wet lump in water. If it is more silty, it will disperse within minutes in the water, while a clayey lump will mainly stick together as one piece.



Silt sticks to the hand



Clay will fall off.



Basic Test 13: Hand Washing test.

Duration: few minutes

Add much more water to the sample to loosen its cohesion and wash your hands with water.

- A gravelly soil does not stick and is easy to wash
- A sandy soil sticks very little and is easy to wash
- A silty soil sticks a lot and is difficult to wash. However, it dries quickly in the sun, leaving a powdery residue which is easily brushed off.
- A clayey soil is easy to wash, but leaves a thin oily film. Sun-drying of this film takes a long time, the clay dries flaky and is then difficult to brush off.



Additional Test 5. Cigar test.

Duration: 15 minutes

This one gives basically the same information as the thread test and the ribbon test. The accuracy of all three is not so high, because they highly depend on the amount of water that you add to the mix. Still, it goes not hurt to do all three of them, as they give an indication of the amount of clay in the soil. They sort of all check out each other.

First sieve the soil with the 425 micron sieve, to remove coarse sand and gravel. Mix the soil into a plastic state, which is easy to mould but does not stick to the fingers. Between the hands, roll a cigar of about 3 centimeter in diameter and 20 centimeter in length. Now gently push the cigar over the edge of one hand, until it breaks. Measure the length of the piece that fell down. Better repeat the test a few times to take an average measurement.

When the broken piece is less than 5 centimeter, sand is high and the clay content is low, and also the cohesion is low.

When the piece is between 5 and 15 centimeter, the soil has a good consistency

When the piece is longer than 15 centimeter, the soil contains too much clay, and the cohesion is (too) high.

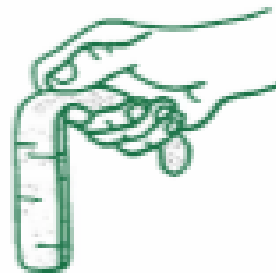

Additional Test 5. Ribbon test.

Duration: 15 minutes

Similar to the cigar test, but this time we press a ribbon between the fingers. Start again with a plastic mix, which is not sticky, but wet enough to permit being rolled into a 15 mm thick cigar. Put the roll in one hand and start flattening it from one end, between the thumb and index finger, until it is between 3 and 6 millimeter thick. Measure the length obtained before the ribbon breaks. Also here it is better to do the test several times, to come to an average value.

The following interpretations are possible:

No ribbon can be made. This means that the soil contains very little clay or even no clay at all.

A short ribbon can be made between 5 to 10 centimeters. The soil contains a low to medium amount of clay.

A long ribbon can be made without any problem, even up to 25 to 30 centimeters. The soil has a very high clay content.

Additional Test 7. Wet Tapping test.

Duration: few minutes

This one, also known as the water retention test, is an additional test to identify whether the sample is more silty or clayey, is carried out on the fines of the soil, including fine sands. It shows the ability of the soil to retain water. Keep in mind that the test is not so accurate, because it highly depends on the amount of water that you add.

First sieve the sample with a 0.425 mm mesh. Make a ball of about 3 centimeter diameter and moisten it with water. It should have enough water to just hold the particles together, without sticking to the fingers. Flatten the ball slightly and hold it in the palm of your hand. Now try to bring water to the surface of the sphere-shaped ball, by shaking it hard, or by tapping the hand with the other hand. The appearance of the ball may be smooth, shiny or greasy-livery. Then squeeze the ball between the index finger and thumb, to see whether the water disappears or not.

The following reactions can be observed, note down which one was discovered:

Rapid reaction: when it takes only 5 to 10 taps to bring water to the surface. This is known as dilatancy, meaning that the soil stops holding on to the water. After squeezing the ball, the water disappears immediately and the appearance of the ball becomes dull again. Continued pressure causes the sample to crack and finally crumble. This is characteristic for fine sands and coarse silt. Note that even a small fraction of clay will keep the reaction from being rapid.

Slow reaction: when 20 to 30 blows are needed, you have a sluggish reaction. Squeezing the ball will not cause it crack and crumble, instead it will flatten out like a ball of putty. This reaction shows that the ball has some clay in it.

Very slow to no reaction: The longer it takes to show any reaction, the more clay the ball contains, as clay does not show dilatancy. Therefore, some soils will not show any reaction at all, no matter how long you shake the sample. When pressing the ball, it retains its shiny appearance.



3.6 Field Testing of Particle Size Distribution

By now we should have a fairly strong suspicion whether the soil is gravelly, sandy, silty or clayey. The next step is to determine the ratio of the grains, in order to come to a final classification of the soil. The basic test can be carried out in the field, but is difficult to interpret without a long experience in soil recognition. The additional tests prove to be of great help, but they have to be carried out at home.



Basic Test 14: Hand Sieving test.

Duration: half hour

Needed is a bucket of water, and a squeeze bottle, such as an empty shampoo bottle. Put a ball in the palm of your hand and remember the quantity. Run water continuously and very cautiously over the soil to remove all silt and clay. Do it very slowly, and don't wash away your fine sands. If you feel that the soil is silty, then you probably wash out a lot of silts. Then try to interpret the percentages by comparing the amount before and after and classify the soil. Note in bold letters which particle is predominantly present.

Gravelly soil : when there is more than 15% gravel in the soil > 15%
 Sandy soil : when there is more than 50% sand in the soil > 50%
 Silty soil : when there is more than 15% silt in the soil > 15%
 Clayey soil : when there is more than 20% clay in the soil > 20%



Additional Test 8: Jar test.

Duration: one day

Although not quite accurate, a very helpful test is the jar test, also known as bottle shake test. It is not fully reliable, because the gravel layer will contain many voids and seems very deep compared to silt and clay, which have very few voids. And as silt and clay swell up, this percentage will also be wrong. Still, it is a helpful indicator to distinguish the ratio between the coarse and fine particles, and it gives insight whether there is a reasonable distribution of the particles, or if the soil contains too much grains of one size.

Sieve a sample with a 5 mm mesh, to remove too large parts. Take a clear jar or bottle and fill it one quarter to one third with soil, then fill it to the top with clean water. Add 1 teaspoon of salt to the jar; this will help to separate the particles. Close the top and shake it well for 2 minutes, place it on an even surface and let it rest for an hour. Examine the contents briefly, then again shake it well and now let it rest for a day.

Coarse grains will have settled first, with gravel on the bottom and sand on top of that. This takes only seconds. Silt however takes about 45 minutes to settle, and clay stays in suspension for more than 8 hours. Organic matter will keep floating on the surface of the water. Generally we can say:

If the two layers of fines on top of the coarse particles are between 25 and 50%, the soil seems promising for earth construction.

If there are hardly any coarse grains, or on the contrary hardly any fines, then the soil is unsuitable for earth construction.





Additional Test 9. Wet Sieving test.

Duration: some hours

The last additional test will distinguish the difference between the coarse grains and the fines with a higher accuracy. For this a pan and burner are needed to dry the sample, a simple kitchen scales, and a 75 micron sieve with a firm brush.

First prepare a sample of soil, by sieving it with a 5 mm sieve, which removes pebbles and too large gravel. Crush the lumps as much as possible. Take about 600 grams of this sample and heat it for about 10 to 15 minutes in a steel pan over a hot fire, as described in chapter 3.2. After most of the water has been vaporized, now weigh 500 grams of this cooked soil with the kitchen scales.

Take the nr. 200 sieve, which has a mesh of 0,075 millimeter. Note down the starting time of the test. Now start running water over the soil in the sieve continuously, so that all the fines are washed out. Rub your fingers mildly over the soil, and be careful that no soil splashes out. A silt trap in your sink will prevent clogging up your drainage system! It may take a while before the out coming water under the sieve starts to become clear again. As soon as this happens, the wet sieving is finished, note down how long this took. Obviously, the more time it took, the more fines are present in the soil.

Now allow the content of the sieve, which are only coarse grains, to dry enough, so that the content can be brushed out of the sieve, into the steel pan. Fully dry this content over a hot fire in about 10 minutes. Now place the contents on the kitchen scales and weigh again. Calculate the percentage of coarse grains, related to the starting weight of 500 grams.



Keep water running through the sieve until the water coming out becomes clear. The residue contains the coarse grains of the sample.

3.7 Field Testing of Shrinkage

The most elaborate test as described in this manual is the linear shrinkage test, also known as the Atcock test. It may be useful especially for tropical and lateritic soils, which tend to shrink more than average soils. Also, the more clay a soil contains, the more it will tend to crack, which may cause severe cracking of your construction!

Since this is definitely an at-home test, this one is not included on the soil recognition form.

Additional Test: Shrinkage test.

Duration: 3 to 7 days

Needed is a wooden or steel mould, with an internal dimension of 60 cm long, 4 cm wide and 4 cm deep. The top is open and the sides of the mould are greased, so that the soil won't stick to it.

Only remove large gravel particles from the soil sample. Prepare a soil mixture with optimum moisture content. This means that the soil does not stick to the fingers, and when a ball is dropped from 1 meter height, it breaks into several bigger lumps. The soil is pressed into the corners with a wooden spatula, and the box is neatly smoothened of at the top, making sure no air is trapped inside. The filled box is exposed to the sun for 3 days, or set aside in the shade for 7 days.

After this period, the soil will have dried and shrunk. If the shrinkage process causes several cracks across the width of the mould and divides the sample in chunks, the soil is high in sand, and low in clay and silt.

If the soil has dried and shrunk as one single piece, and its surface exceeds the top of the mould in a curved shape, then it contains a lot of clay.



Cracks and chunks

Dried as one single piece

Now push all the soil parts to one side of the mould, and measure the difference in millimeters. The percentage of shrinkage, and the approximate clay content can be calculated by:

$$\text{Shrinkage} = \frac{\text{length of internal mould} - \text{length of dried sample}}{\text{length of internal mould}} \times 100\%$$

$$\text{Approx. clay content} = \frac{\text{length of shrinkage}}{\text{length of internal mould}} \times 500\%$$

3.8 Field Testing of Finished Products

This is rather done at home than in the field, because some heavier equipment is needed. At first some test blocks without any stabiliser are made. For this we can use the block making machine, which has already been purchased if we plan to make stabilized mud blocks. An alternative is to make moulds and ram a few blocks.

First, sieve the samples. Gravelly soil is done with a rough 10mm sieve, to take out the big gravel. Sandy, silty and clayey soil can be done with a 6 mm sieve, to take out the lumps. Don't sieve these soils with heavy wind, especially not sandy soil, because you loose all your silt and clay! Then add some water, mix it by hand, remove the lumps and keep adding water until the mix is hand dry. Determine the optimum moisture content by dropping a ball from one meter high, as described in chapter 3.3.

Press blocks and use a penetrometer to check the compression. Leave the blocks to dry for one week. Then check if the block is crumbly or firm, has hard corners, or has cracks. A crumbly structure indicates a lot of gravel, fine hair cracks indicate silt and a hard block with many cracks but hard corners contains a lot of clay. Note on these pictures also the depth of the penetrometer checks.



Gravelly soil



Sandy soil

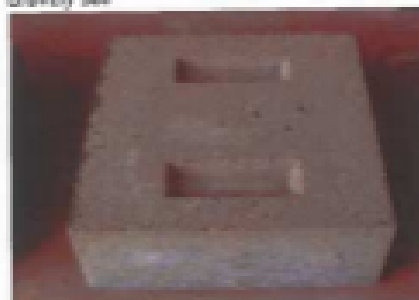

Silty soil



Clayey soil

Penetrometers are used to determine the resistance to penetration of a soil or a finished product, known as the bearing capacity. The one we use is a pocket-sized penetrometer, which we can use for measuring the compaction of a foundation trench, a rammed earth foundation or a freshly compressed soil block.

The 6 mm calibrated mark represents 5 kg/cm². If it goes in only 1 mm, it represents around 30 kg/cm². This is done in the wet strength state, which equals around twice as much compression in the dry state.

SMART SHELTER FOUNDATION

Field Testing

When it goes in less, the block is either strong, but also could be too dry.
When it goes in deep, the block is too wet, or the compression is not enough.

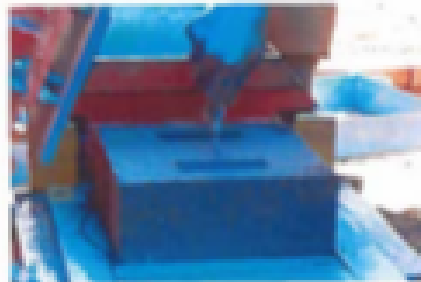

Test the compression of freshly made blocks with the penetrometer.

As explained in chapter two, a compression machine can be used to measure the load bearing capacity of a partially or fully block. But as these compression tests in the lab usually are not always reliable, it is better test it yourself by a bending test.

Needed are a lever with a plateau, and a weighting device. Weigh 10 blocks and take the average weight. Also weigh the weight of the loading plate. Place one block on the two compression points and keep adding blocks on the loading plate, until the block breaks.



Testing the strength of the blocks by a home-made bending test.

Formula 1: Force applied on the block: $F = (\text{load on the plate} + \text{load of plate itself}) \times 5$

Formula 2: bending crushing strength $Cb = \frac{3 \times F \times L}{2 \times W \times H^2}$ in kg/cm²

Formula 3: compression crushing strength $Cc = \frac{F \times L}{1,56 \times W \times H} \times \sqrt{1 + \frac{L^2}{4 \times W^2}}$

L = distance between the two lower compression points

W = width of the block

H = height of the block

1,56 = ratio; only for blocks with a proportion of $0,23 \leq (H / \text{length of block}) \leq 0,62$

Less conventional solutions are to drop a fully cured block from 2 meters height, or to load a truck with 20 people and drive over some blocks. When they don't break, they seem ok for construction...



3.9 Field Testing Summary

Many simple tests can be conducted on small samples of soil. Which ones you carry out totally depends on where your site is located, on the tools available, and of course on your experience. It is simply a matter of starting to practice the tests and you will gain more and more feeling along the way.

In the middle of nowhere your senses and some water will suffice, as described in the sensitive tests. When a bit more time is available, you can do some additional testing at home. Basically, what works for you in convincingly determining the soil quality, is what you will do. I especially find the sieving test with a 75 micron sieve very helpful.

Quite a few tests complement the others, just giving you more certainty about your suspicions of the soil characteristics, or on the other hand they could rule out certain options. Keep in mind that many additional tests, such as the thread test and the ogar and ribbon test for plasticity and cohesion, are very dependent on the amount of water you add. Therefore they are not very accurate and not conclusive at all, but they could be helpful for the overall feeling about your samples. But that is exactly why these are labeled as additional tests.

After testing always make a few test blocks. These results give you the actual strength and behavior of your constructions!

All the basic and additional tests have been summarized in the Soil Recognition Forms. These two pages can be found under appendix 1, at the end of this manual.





4. Soil Stabilization

Many different earth techniques are being practiced all over the world. Some soil types are very suitable for certain types of construction, others cannot be used at all. This chapter briefly explains why and how we sometimes need to modify our soil to improve its characteristics or suitability for different earth techniques.

Soil modification and soil stabilization is not the main topic of this manual, so for additional and more detailed information regarding this subject, please refer to the bibliography at the end of the manual.

4.1 Earth Construction Techniques

The variety of different techniques can be grouped into 4 groups, which refer to the type of construction process, according to the hydrous state of the soil mixture. Within these 4 groups, 12 main types of construction can be distinguished:

Technique	Hydrous State	Soil Consistency
1. dug out 2. cut out 3. filled in	solid or dry	solid solid dry soil
4. covered 5. compressed (rammed earth, cseb)	humid	humid aggregation moist soil
6. shaped 7. stacked (cob) 8. moulded (adobe) 9. extruded	plastic	semi-solid paste solid paste semi-soft paste soft paste
10. daubed (wattle and daub) 11. formed 12. poured	liquid	soft paste liquid liquid

1. Dug out. These are dwellings that are directly cut out of the earth's crust or the hills.
2. Cut out. Blocks of earth are directly cut out of the ground. Harder blocks are cut out of laterite soil or soft rock. Organic or earthen blocks are called sod or turf.
3. Filled in. Hollow frameworks are used to hold the soil in its place. The materials range from textiles and latticework to bags, boxes and car tires.
4. Covered. Structures that are covered with a layer of soil, or a living green roof, for thermal comfort.
5. Compressed. Blocks or walls are formed by compressing soil in moulds or in a formwork. These modernized techniques are being used more and more nowadays, such as rammed blocks, rammed earth and compressed stabilized earth blocks (cseb).
6. Shaped. Thin walls are directly shaped by hand, with a plastic soil mix. Many granaries have been built like this in Africa.
7. Stacked. Thick walls are formed by stacking hand-shaped balls or loafs of clayey soil on top of each other. Known as cob, of which many examples can be found in Yemen.



8. Moulded. A plastic mixture of soil, usually reinforced with straw, is moulded by hand or in a formwork. Then it is left to dry in the sun. The common name is adobe, derived from the Arabic word 'thobe', which means brick.

9. Extruded. A soil paste is extruded by a powerful machine. Quite expensive and the moulds wear out quickly.

10. Daubed. A clayey soil is mixed with fibers or straw and then used as an infill in a formwork. Commonly known as wattle and daub.

11. Formed. A clayey slurry with a lot of straw fibers, which can be stacked with a large fork. Blocks can also be used as insulation in floors.

12. Poured. A very gravelly liquid soil which is poured in a formwork. The quality is difficult to control.

4.2 Objectives of Soil Stabilization

The purpose of stabilizing a soil is to modify the system of grains, water and air in the soil, in order to improve and obtain long-lasting properties which are compatible with a particular application.

Only two characteristics of the soil itself can be improved, which are the structure and the texture. These can be adjusted in the following areas:

- Reducing the volume of voids between the particles; affecting the porosity.
- Filling up the voids which can't be eliminated; affecting the permeability.
- Improving the links between the particles; affecting the mechanical strength.

The main objectives that are being pursued are:

- Obtaining a better mechanical performance, by increasing the dry and the wet compressive strength.
- Reducing the porosity and changes in the volume of the soil, such as shrinking and swelling by variations of moisture content.
- Improving the resistance to climatic conditions such as wind and rain, by reducing the surface abrasion and by increasing the waterproofing.

Nowadays adding stabilizers to a soil seems the common way to improve its quality. However, stabilization is not always required and should be avoided if possible. Stabilization can complicate the production processes, as it requires longer preliminary studies of the behavior of the soil. More importantly, it may substantially add up to the cost of the final product, sometimes between 30 up to 50% of the total material cost.

It is not necessary to stabilize the soil, when the material is not exposed to water or moisture, following an appropriate design. This may include building elements such as interior walls, protected walls and rendered walls.

On the other hand it is necessary to stabilize the soil mixture when the walls are very much exposed to the weather conditions, such as rain and wind, or to damp site conditions. Also stabilize blocks and walls that need to have a higher compressive strength, such as multiple storey buildings, or buildings in earthquake prone areas.

4.3 Methods of Soil Stabilization

There are three basic procedures for stabilization of soil, which are:

Mechanical stabilization: The properties of the soil are modified by compacting its structure. The compression gives the soil more cohesion. The density, mechanical strength and the compressibility all increase, while its permeability and porosity decreases. The less porous the material is, the higher the strength will be.

Physical stabilization: the properties of the soil are modified by controlled mixing of its texture. It can be done by removing a component, like sieving out the gravel. Or you can add a component to the soil, such as sand or clay. When a stone quarry is nearby, you can use quarry dust instead of sand; it is cheaper and better for the environment.

Chemical stabilization: other materials or chemical products are added to the soil to modify its properties, such as binding or coating the grains. The most commonly used ones are lime or cement. Chemicals such as bitumen and resins are not recommended. The cost is usually high, they are difficult to process and not available everywhere.

These procedures can be divided into 6 different methods:

1. **Densification:** It refers to the increased compression in the final state, which can be achieved in 2 ways. The first one is by forcing out as much air as possible by high compression; this changes the structure of the soil, as the particles are redistributed. The other way is to modify the texture, by filling up the voids of each group of particles by another group of particles. For this the particle size distribution has to be perfect.
2. **Reinforcing:** Here the soil is reinforced by an addition of natural fibers, such as straw or sisal, by animal hairs or by synthetic fibers. This approach creates a so-called 'anisotropic network of limiting movement' and it reduces the risk of shrinkage. It can be used for a plastic clayey mixture, such as for adobe or wattle and daub. Reinforcing is not to be used for rammed earth or compressed earth blocks.
3. **Cementation:** By filling the voids with an insoluble binder, which coats the grains and holds them in an inert matrix that can resist all the movements of the soil. The main consolidation reactions occur between the stabilizer and the sandy fraction of the soil. The most common type used is Portland cement, or sometimes fly ash. Fly ash is always added in combination with cement, because it does not bind enough by itself.
4. **Linking:** This works on the clay particles in the soil by adding lime. Lime helps clay to stick properly when it becomes wet. By adding lime a stable bond is created between the sand and the clay, which by means of a pozzolanic reaction creates a new and insoluble inert material.
5. **Imperviousness:** The aim is to reduce erosion by water, as well as the swelling and shrinking of the material, by surrounding every grain with a waterproof film. One method of stabilization is that all the voids in the soil are filled with a material that is unaffected by water, such as bitumen, but which is difficult to mix. The other method is to add a material to the mix which expands upon the slightest contact with water, thus preventing infiltration of the pores. Bentonite is such a dispersion material.
6. **Waterproofing:** By creating a waterproof filter on the skin, or surface of the structure. This is to avoid water absorption (going in), or to avoid adsorption (going out). For the interior you can use paints and plasters, such as lime. Only use cement based paints; never use chemicals or acrylic paints, because they block the breathing of the walls.

4.4 Improvement of Soils

Handle these rules of thumb with care, as they are not pure fact. There are so many different types of soils and they may react differently than expected. For instance, gravel and sand don't change the soil composition much, because of the inert character of these particles. Silt and clay however may change the composition of the soil very much.

The table below shows the limits of suitability for the 12 different earth techniques. Always be aware that these limits are approximate and the permitted tolerances may vary considerably from one site to the other.

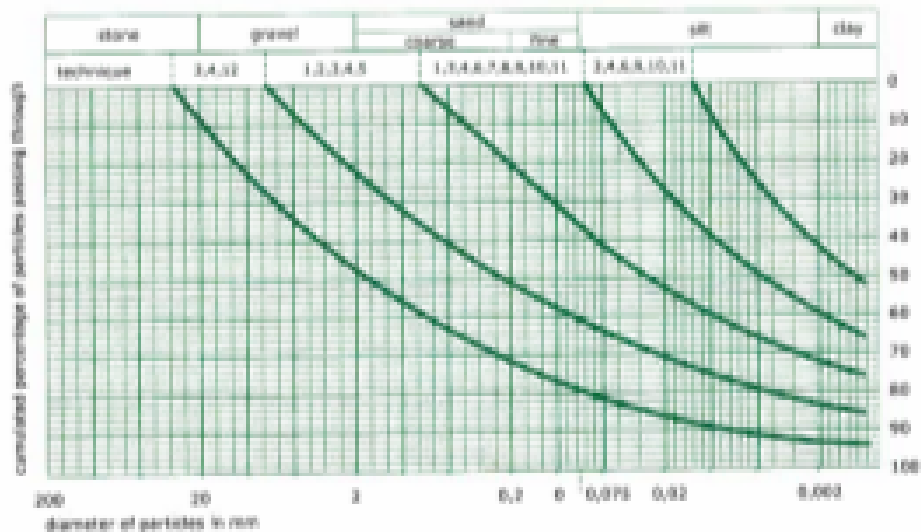

The grain size distribution of Cement Stabilized Earth Blocks and rammed Earth fall in the same range. The mix for rammed earth is preferably more sandy, that's all the difference. The ideal percentages for CSEB are 15% gravel, 50% sand, 15% silt and 20% clay. But these limits can vary as much as the figures below; they may even be outside of these, and still perform well.

- Gravel: 0-40%
- Sand: 25-80%
- Silt: 10-25%
- Clay: 0-30%

Ideally the percentage of stabilization falls within the limits as given in the table below. The maximum percentage mainly depends on the cost. For example, concrete with a ratio of 1:2:4 contains 13% cement by weight. But if you would add 13% cement to silt, it will never reach the strength of concrete; so it's useless to do. It is recommended to make a few test blocks with different modifications, to determine the best performance.

Stabilizer	Soil type	min %	av. %	max %
cement	sandy	3	5	7 to 8
lime	clayey	2	6	10



Generally the particle size distribution does not follow the ideal curve and the soil is predominantly gravelly, sandy, silty or clayey. In those cases follow these guidelines:

Gravelly Soil in general:

Sieve with 8 to 10 mm mesh

Maximum 15 – 20% may pass trough

The maximum diameter is 10 mm

If it is too gravelly, add clayey soil, although it is difficult to mix

If there is enough good clay in the soil, use 3 to 4% cement to stabilize

If it is too gravelly, use 6% cement to stabilize

Sandy Soil in general:

Sieve with 8 to 10 mm mesh, this is only to loosen and aerate the soil

Don't sieve in windy areas, you will loose too much clay

If not too sandy, use 5% cement to stabilize

If too sandy, use 6% cement to stabilize, in order to enhance the cohesion. Otherwise it will be impossible to press the blocks.

If there is enough good clay in the soil, use 4% cement to stabilize

Silty Soil in general:

Be very careful with determining silt, as it can behave like clayey soil, or fine sandy soil

Sieve with 6 mm mesh if the silt is on the clayey side

Sieve with 10 mm mesh if the silt is on the sandy side

Add 10 to 20% coarse sand, because we need particles to bind.

If it is impossible to press blocks, it might have been fine sandy soil already!

Use at least 6% cement to stabilize

Clayey Soil in general:

Sometimes crush it first, and sieve it with a 6 to 8 mm mesh. It may create quite some lumps and waste. Here are three possibilities for stabilization:

mix it with 5 to 6 % cement and 20 to 40% sand, or

mix it with 6 to 7% lime and 10 to 15% sand (check with press if sand is needed), or

mix it with 2% cement and 5% lime (lime reacts slowly and cement speeds that up).



4.5 Stabilization Summary

The following table gives an overview of the different soil classifications, and explains which earth techniques are suitable for them. It also provides information about how to modify the soil mixture, if necessary.

As can be seen, for cement stabilized earth blocks (cseb) and rammed earth (r.e.), preferably the soil needs to be coarse and sandy. The more fines it contains, the less suitable it is for these techniques. Especially high amounts of silts have a negative effect on them. The soil can be modified up to a certain level, but at some point the costs will become too high, and it is better to directly find a soil that is more suitable.

Classification	Technique	Stabilization / remarks
gravelly	1. fill in 2. covered	- if the clay content is enough
clayey gravel	1. fill in 2. covered 3. r.e. & cseb	- soil is suitable soil - some sand might be needed, plus 5% cement stabilization gives good result
sandy	1. fill in 2. covered 3. r.e. & cseb 4. cseb	- if the soil is cohesive enough, 5% cement will increase cohesion and resistance - if the soil and clay are not too strong, 1% cement stabilization may be useful
clayey sand	1. fill in 2. covered 3. r.e. & cseb 4. cseb 5. lime	- some sand might be needed, plus 5% cement stabilization gives good result - if the soil is cohesive enough to form a ball
silt	1. fill in 2. covered 3. cseb 4. lime	- sand might be needed, plus 5 to 10% cement stabilization
sandy silt	1. fill in 2. covered 3. cseb 4. lime	- it requires a bit more cement, 5 to 10% cement stabilization gives good result
clayey silt	1. fill in 2. covered 3. cseb 4. lime	- if the soil is cohesive enough - a stabilization with sand or straw might be needed - a stabilization with sand or straw might be needed
clayey	1. fill in 2. covered 3. cseb 4. lime 5. straw 6. crushed 7. water and slush 8. rammed	- some natural stabilizers or lime will be needed - a stabilization with sand or straw might be needed - a stabilization with sand or straw might be needed - an improvement with sand, plus 5% lime stabilization might be needed - a stabilization with sand or straw is needed - a very high clay content is necessary
gravelly clay	1. fill in 2. covered 3. r.e. & cseb 4. lime	- some sand might be needed, plus 5% lime stabilization will be useful - a stabilization with straw might be needed
sandy clay	1. fill in 2. covered 3. cseb 4. lime 5. straw 6. crushed 7. water and slush	- some sand might be needed, plus 5% lime stabilization will be useful - some natural stabilizers or lime might be needed - a stabilization with straw might be needed - an 5% lime stabilization will be useful - a stabilization with straw will be needed
silt clay	1. fill in 2. covered 3. cseb 4. lime 5. straw 6. crushed 7. water and slush 8. rammed	- a stabilization with sand or straw might be needed - a stabilization with sand or straw might be needed - an improvement with sand, plus 5% lime stabilization might be needed - a stabilization with sand or straw is needed - a very high clay content is necessary
sandy gravel silt gravel gravelly sand silt sand gravelly silt		- all unsuitable for earth construction

5. Soil Testing in Kaski District of Nepal

This chapter gives an overview of all the tested soil samples, which were taken from three different areas in Kaski District. Most have been tested quickly and on the spot, revealing an overall impression of the soil structure. Around 30 samples have been brought back to Pokhara where they have been examined more closely. These results are shown in the following paragraphs. The last paragraph gives some conclusions and recommendations for further research.

5.1 Taking Samples in Kaski District

At first, many soil samples were collected from the remote villages and hill areas where Smart Shelter Foundation was constructing earthquake resistant mountain schools. They are located in the Village Development Committees (sub-districts) of Deurali, Thumki, Rupakot, Kalka, Bhachok and Hjure. To have an idea about the distances; from Pokhara to the border of Thumki VDC is approximately 40 kilometers, which is 4 to 5 hours by bus over the steep and dusty mountain roads, or 6 to 8 hours of walking.

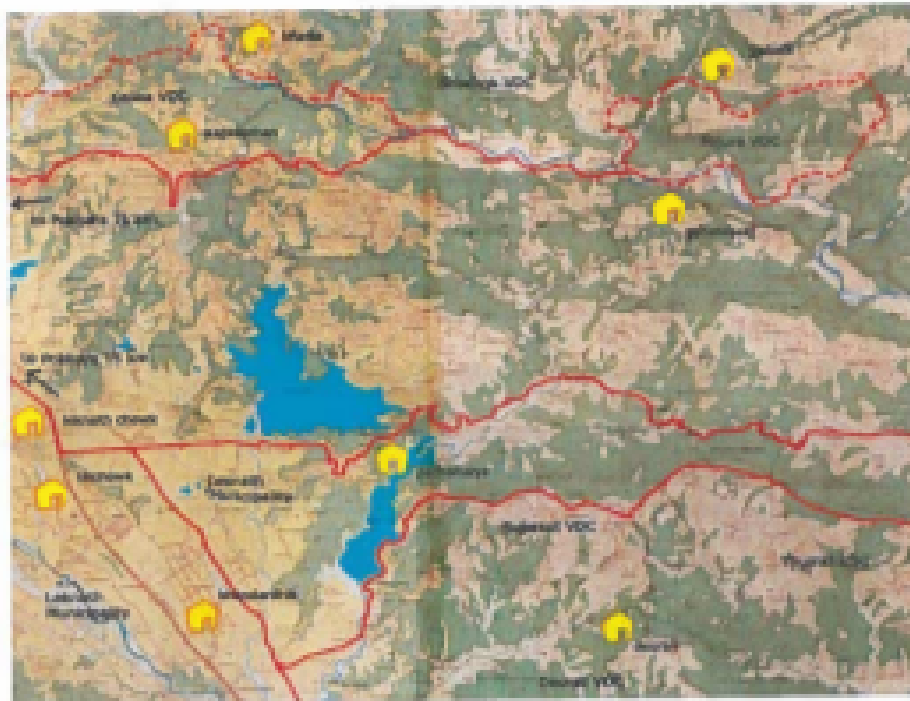

Before taking the mountain soil samples, we inquired in the villages where they collect the soil that they use for their construction purposes, such as the mud mortar in the stone walls. Usually it is taken directly from the building sites, in some cases it is collected from an excavation area that is locally well known for its 'mato ramro', meaning 'beautiful soil'. The left picture on the next page shows an example.

In many cases samples had to be rejected, as they contained too much organic matter. People mostly live from farming activities and therefore classify agricultural land as 'mato ramro', which is understandable from their point of view.

SMART SHELTER
FOUNDATION
 Soil Testing in Pokhara

Mountain soil on slopes, and especially soil adjacent to the mountain roads, generally has a very layered, but rocky texture. The outer surface of these walls is constantly exposed to the weather, making these rocks are quite soft and crumbly. These rocks may be in some state of erosion or transition phase between rock and soil. Such rocky soils have not been sampled and tested as they are unsuitable for making stabilized soil blocks.

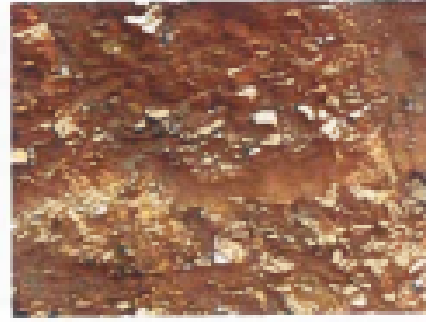

The second batch of samples was taken from the area between the city and the mountain villages, better known as the plain area of Leknath Municipality. This former river bed and flooding area is very fertile and commonly used for agricultural practice. Recently, more and more land is being utilized for construction purposes. Samples were mostly taken from slopes next to rivers and former river beds, and from foundation trenches of newly built houses.

Thirdly, many samples have been examined which were taken from within and closely around the city of Pokhara. Here the soil turned out to be very hard and it contains a lot of big rocks and stones. I specifically looked at construction sites and the many drainage works that took place all over Pokhara. This saved me a lot of hard work of digging holes, and for our purpose it also makes sense to test soil at construction sites. This will give an idea whether soil blocks can be a good alternative for the common construction practice. The picture on the left is made at a typical building site and it shows that already at one feet deep, the soil becomes very rocky. The picture on the right shows a small landslide and confirms that many parts of the city area are built on rock ground with just a thin top layer of finer soil of about one or two feet thickness.



5.2 Test Results of Mountain Area Soils

The first impression of all mountain soils is, that the texture is very fine and that the samples hardly contain coarse particles. This could already be seen during the on-site sensitive tests, and the more precise sieving tests at home confirmed this, as can be seen in the schedule below.

location	depth	particle size %	classification	remarks
Deurali, Deurali VDC, +450	1 feet	10-15-50-25	clayey silt	
Deurali, Deurali VDC, +450	2 feet	10-15-45-30	clayey silt	
Gahala, Mjura VDC, +1100	on slope	5-25-20-50	clay	soft rock
Gahalaesi, Mjura VDC, +450	on slope	5-10-50-35	clayey silt	
Gahalaesi, Mjura VDC, +500	on slope	10-25-30-35	silty clay	soft rock
Kalkaethan, Kalka VDC, +1150	2 feet	5-20-40-35	clayey silt	soft rock
Shawa, Kalka VDC, +750	2 feet	5-25-40-30	clayey silt	very fine sand
Pachhaiya, Rupakot VDC, +480	2 feet	10-10-20-60	silty clay	soft rock
Pachhaiya, Rupakot VDC, +750	2 feet	10-30-20-25	silt	soft rock

Generally we can say that the mountain soils are easy to excavate, especially away from slopes and roads. Needed for the most common earth techniques (adobe, stabilized blocks and rammed earth) is a ratio of coarse particles versus fine particles of around 70 to 30%. But after testing it appeared that the ratio of the mountain soils usually is the other way around; sometimes even 15% coarse versus 85% fines! So unfortunately the texture of most tested samples is too fine for our proposed techniques.

The fact that mountain soils are very fine can be seen in the direct surroundings as well. In the dry season the mountain roads are covered with a thick layer of dust, sometimes up to a feet thick. The sky can become very hazy and visibility is low when the wind blows these fine particles into the air.

What is also worrying, is that almost all samples contain pieces of soft rock. They look like stones and gravel, but certainly are not. Different types of rock have been identified, which on the outside all look very hard, but which can be crumbled easily by pressing them between the fingers. Of course the bigger pieces can be sieved out easily. But it will be very difficult, if not impossible, to sieve out the smaller but soft rocky particles. These particles are likely to have a negative effect on the quality of stabilized blocks, which may not achieve the necessary compression during pressing. Also they may be sensitive to breaking and to erosion of its surfaces.

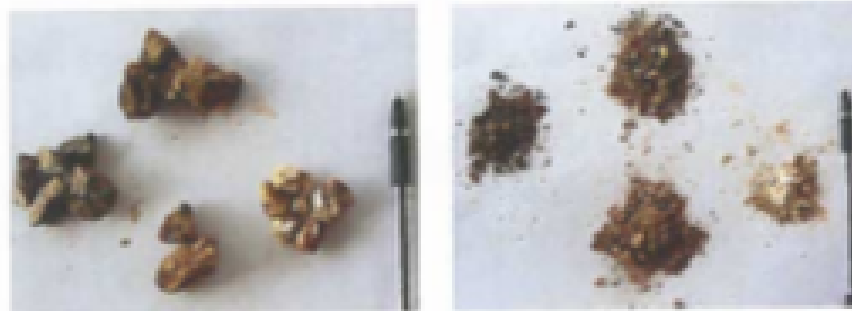

These pictures show four different types of rock, which were found in the samples of Pachhaiya. They could all be crumbled simply by hand.

5.3 Test Results of Plain Area Soils

The results of the tested samples in the plain area are similar to those from the mountain areas. Which is quite understandable, since a large part the plain area used to be a former river bank. Also it gets flooded during monsoon by water that comes from the mountains, bringing down enormous amounts of fine particles. The plain area is considered to be very fertile ground for agricultural purposes.

Many houses are currently been built on these former paddy fields, close to the highway between Kathmandu and Pokhara. This made it very easy to collect samples from the foundation trenches. Unfortunately many samples had to be rejected right away, as they contained too much organic matter, which was to be expected.

location	depth	particle size %	classification	remarks
Bhandarik, Lekhnath, +550	3 feet	15-25-60-30	silt	very fine sand
Lekhnath Chowk, +700	1.5 feet	10-10-80-30	clayey silt	
Lekhnath Chowk, near river bank	on slope	5-15-80-30	clayey silt	
Talchowk, Lekhnath, +600 m	2 feet	2-13-85-30	clayey silt	
Sati River Bank, near Harnpai	1 feet	1-19-80- 3	silty sand	organic matter

Some samples were also taken at the Sati river bank outside of Pokhara, because more sand was expected here. Which turned out to be correct, but the problem was that the soil is merely a thin layer of top soil directly situated on the bedrock, and it contained a large amount of organic matter. Also many soft but shiny particles were visual, which could be mica, see the left picture. It is impossible to make strong blocks when mica is present in the soil.

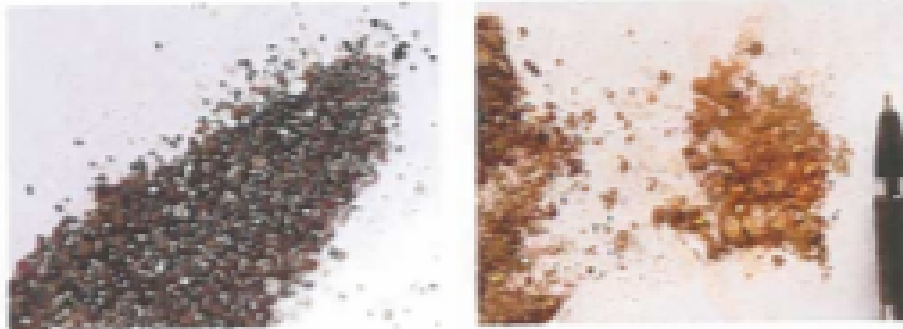

Similar as in the mountain areas, the tested soils are too fine to be utilized for compressed stabilized soil blocks. Also these samples contained a lot of soft stone particles, which may have a negative effect on the compression strength of the blocks. The right picture shows an example from Lekhnath Chowk, where the particles that look like gravel can easily be grinded to powder between the fingers.

5.4 Test Results of City Area Soils

In the city area of Pokhara the results of the samples was slightly different, but not much better than the samples from the mountains and the plain area. The soil in the Pokhara region is very rocky with a relative thin layer of top soil. Also the city area of Pokhara used to be agricultural land, so in many cases the top layer has mostly fine particles such as silt and clay, and it contains lots of organic matter.

location	depth	particle size %	classification	remarks
Gimal Chowk, drainage 600+	4 feet	10-15-45-30	clayey silt	soft rock
Phoolbari, house construction 14	1 feet	10-15-45-30	clayey silt	organic matter
Phoolbari, house construction 18	2 feet	10-30-40-20	silt	soft rock
Phoolbari, house construction 24	1 feet	5-10-35-50	silty clay	former agri land
Phoolbari, house construction 28	2 feet	15-20-40-25	silt	soft rock
Basker school 1	1 feet	5-10-50-35	clayey silt	former agri land
Basker school 2	2 feet	10-15-35-40	silty clay	soft rock
Manjpal House construction	2 feet	5-10-45-40	silty clay	mustard seeds
Manjpal Bogas tank construction	5 feet	20-55-10-15	sand	soft rock

The high presence of rock means that it is difficult to dig in the ground, and many stones must be removed by sieving the earth. The ratio of stones versus soil is often more than 50%, so the yield of useable soil will be relatively low and labour costs will be high.

Some samples were taken from deeper, like 4 or 5 feet deep, and these contained more sand and gravel. After closer examination, the gravel again turned out to be soft rock that seems to be in a state of erosion and easily falls apart after applying a light pressure. Such as being the case for the mountain and plain area soils, the city soils will be difficult to use for stabilized compressed earth blocks.

The pictures below show a typical stone as found in many samples in the city, in this case in the city area named Phoolbari. Many houses are being constructed here recently, on former paddy rice fields.

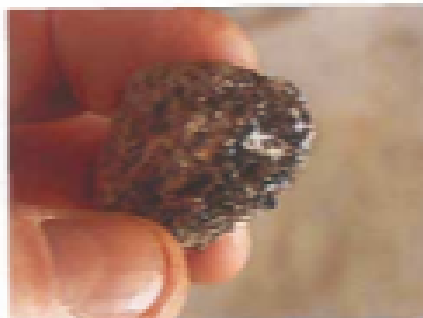

5.5 Recommendations for Further Testing

The test results of all soils in the mountains, the plain area and in the city are not too hopeful as it comes to suitability for making compressed earth blocks. And that is a pity, as this technique is the easier one to make earthquake resistant; an absolute must given the high risk of earthquakes in Nepal! The soils are either too fine and silty, sometimes with quite an amount of organic matter. The organic soils should be rejected, and the fine soils must be complemented with large quantities of coarse sand, thus increasing the price of the method. On the other hand many soils are too rocky, usually containing soft rock pieces that look like gravel. These may affect the compressibility of the blocks negatively. But perhaps some of these soils can be used for making rammed earth or adobe blocks.

The first recommendation is regarding compressed soil blocks. What should be done is to purchase or find a block press and make a few test blocks with different mixtures. Soils can be used with and without the soft rock particles, and different ratios of sand can be added. After curing they need to be taken to a polytechnic or university, where they can be tested with a compression machine. Only then the actual behavior of the soil and the real strength of the blocks will be known.

There is a great possibility that the mountain soils, and the soils around Pokhara are unsuitable (or very difficult at the least) for making compressed blocks. Still, that does not mean that the technique cannot be used in Nepal at all. Sonam Wangchuk of SECMOL and Satprem Maini of Auroville Earth Institute in India have built several earthquake resistant schools with compressed earth blocks in the Terai region. Their websites can be found in the bibliography. It has to be mentioned that the soil here was difficult to work with as well. Shown are 2 pictures of an earthquake resistant school made with CSEB in Bardiya.



And this is an example of a social housing project at Kanchanpur in the far west of Nepal, carried out by Shelter and Local Technology Development (SLTD) Centre in Kathmandu.



SMART SHELTER FOUNDATION

soil testing in India

If the mountain soil indeed turns out to be unsuitable for pressing blocks, then it is worth to take a look at the other earth techniques. So the second recommendation is to explore the behavior of rammed earth for the rocky soils and adobe blocks for the finer soils.

Many castles, forts and monasteries which have been built with rammed earth can be found in different parts of the Himalaya. Some of them are already centuries old, but are still standing strong and many monasteries are still in use today. In Ladakh, the northern province of India, many fine examples can be seen in Leh, Shey and the historic site of Basgo. The picture on the left shows the Basgo Rabtan Lhartsokhar Castle. In Nepal many fine examples can be found in the Mustang region and on the Annapurna Circuit north of Pokhara, in the villages of Kagbeni, Jharkot and Muktinath, where the technology is still being practiced. The picture on the right shows the Kag Chode Thupten Samphel Ung monastery in Kagbeni, which was established over 500 years ago. An interesting website about historic rammed earth is listed in the bibliography.

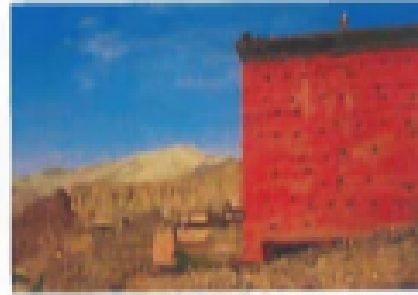

The other technique of interest is adobe, where blocks are made by forming soil with simple moulds and then leave them to dry in the sun. This technique is especially suitable for the finer soils containing more clay and silt; soils up to 50% of clay particles can be used. A stabilizer may be needed, such as sand, straw or rice husk. At first a variety of different mixes should be prepared, in order to test which ratio of ingredients develops the least shrinking and cracking. The Nepali organization Abari is doing interesting work with adobe, and with rammed earth as well, as can be seen on the left picture. Their website is mentioned in the bibliography. The picture on the right shows a Nepali worker, who is making adobe bricks with a simple wooden mould. Please be aware that adobe blocks are relatively brittle and that it is not easy to make such structures earthquake resistant!

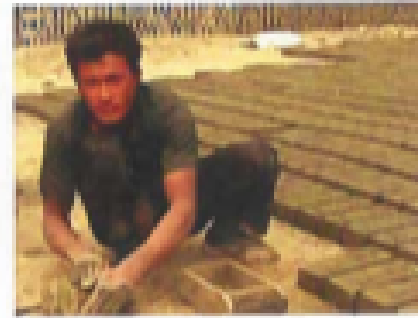

It is my belief that there are more than enough possibilities for earth construction techniques in Nepal, and everywhere in the world as well. So let's continue exploring this beautiful, cost-effective and eco-friendly material!



6. Bibliography

Bin a Rashid, A.S., *Determination of Plastic Limit of Soil using Modified Cone Penetration Method*, Faculty of Civil Engineering Universiti Teknologi Malaysia, downloaded pdf file, 2005.

Amoux, S., Douline, A., Maini, S., *Production and Use of Compressed Earth Blocks, a Training Manual for Technicians and Entrepreneurs*, CRATerre-EAG, Auroville Earth Institute, 1992.

Easton, D., *The Rammed Earth House: revised edition*, Chelsea Green Publishing Company, 2007.

Fratta, D., Aguetant, J., Roussel-Smith, L., *Introduction to Soil Mechanics Laboratory Testing*, CRC Press, Boca Raton, 2007.

Geotechnical Engineering Bureau, State of New York Department of Transportation (2007), *Test Method for Liquid Limit, Plastic Limit and Plasticity Index*, downloaded pdf file, 2007.

Globe, *Particle Size Distribution Protocol*, downloaded pdf file, 2005.

Head, K.H., *Manual of Soil Laboratory Testing, volume 1: Soil Classification and Compaction Tests*, third edition, Whittles Publishing, Carthness, 2006.

Heubert, H., Guillard, H., *Earth Construction: A Comprehensive Guide, Practical Action*, 1994.

Intermediate Technology Development Group Zimbabwe, *How to Make Stabilised Soil Blocks*, Technical Brief, Practical Action, downloaded pdf file.

Maini, S., *Earth as a Raw Material*, Auroville Earth Institute, downloaded pdf file.

Maini, S., *Soil Identification for Earth Construction*, Auroville Earth Institute, CDRC Publication, 1997.

Maini, S., *Soil and Stabilization*, Auroville Earth Institute, 1995.

Rigassi, V., *Compressed Earth Blocks, Volume 1. Manual of Production*, GATE Publication, 1993.

Stutz, R., *Appropriate Building Materials: updated edition*, SKAT Publication no. 12, IOTG Publishing, 1986.















Recommended websites

Auroville Earth Institute: www.earth-auroville.com

Sonam Wangchuck's School in 20 Days: www.usc.du/bw98936.asp

Historic Rammed Earth: www.historicrammedearth.co.uk.

Abari Nepal: www.abari.org

Basic Field Tests		Sample Characteristics	Address
Date of Testing:		Location of Sample:	Name of Sampler:
Ref. / No. of Sample:		Depth of Sample:	Organization and Address:
		Special Circumstances:	
Structure and Texture		possibilities	result
 1. visual use dry sample		granular (grainy), fragmented (sandy), or continuous colour description	structure: colour:
 2. touch use dry sample		coarse, medium coarse, fine, or fine with lumps lumps are powdery (silt), or very hard (clay)	texture: lumps:
 3. smell few drops of water		rotten, starchy or agreeable does the sample contain humus (yes/no)	smell: humus:
 4. taste		sharp and gritty (coarse), or soft and powdery (fines) lumps stick to tongue (clay)	texture: stickiness:
Compressibility		possibilities	result
 5. compression little more water		gravelly soil requires much strength, but very short pressure sandy soil requires some strength, but short pressure (low) silty soil requires little strength, but medium pressure (med.) clayey soil requires very little strength, but long pressure (h.)	compressibility:
 6. ball drop enough water for cohesive ball		one lump (clay), several big pieces (well-graded) or shattered (gravel/sand)	pieces:
Plasticity		possibilities	result
 7. shape enough water for cohesive ball		gravelly soil is very difficult to shape (low) sandy soil is difficult to shape (low) silty soil is quite easy to shape (medium) clayey soil is very easy to shape (high)	plasticity:
 8. elasticity enough water for cohesive ball		gravelly soil breaks very easily, not elastic at all (low) sandy soil breaks easily, little elastic (low) silty soil breaks after some length, acts elastic (medium) clayey soil breaks after long pull, very elastic (high)	elasticity:
 9. adhesion enough water for cohesive ball		gravelly soil is very easy to penetrate, ball crumbles (low) sandy soil is easy to penetrate, knife stays almost clean (low) silty soil is harder to penetrate, stains knife easily (med.) clayey soil is hard to penetrate, stains blade a lot (high)	adhesion:
 10. shine enough water for cohesive ball		gravelly soil has a very rough surface with many voids sandy soil has a rough surface with some voids silty soil has a smooth, but dull surface clayey soil has a smooth, but shiny surface	rough, dull or shiny:
Cohesion		possibilities	result
 11. absorption enough water for cohesive ball		in gravelly soil the water disappears very quickly (low) in sandy soil the water disappears quickly (low) in silty soil water disappears slowly, the sides crack (med.) in clayey soil the water stays for a long time (high)	cohesion:
 12. sticking make quite wet		if it sticks to the hand, the sample contains a lot of silt, if it creates oily water but falls off, it is clay.	silty or clayey:
 13. hand wash keep water running		gravelly soil does not stick and is easy to wash (low) sandy soil sticks very little and is easy to wash (low) silty soil sticks a lot, is difficult to wash, but dries powdery clayey soil is easy to wash, leaves a thin oily film, dries fatty	cohesion:
Particle Size Distribution		possibilities	result
 14. hand sifting		approximate percentages of the particles	% gravel: % sand: % silt:











keep water running

No. test:
% clay:
**SMART SHELTER
FOUNDATION**
SOIL IDENTIFICATION FORMS

 form 2/3
www.smartshelterfoundation.org
info@smartshelterfoundation.org
Additional Field Tests

Ref. / No. of Sample:

Structure and Texture	possibilities	result
 1. ball drying enough water for cohesive ball	if it quickly falls apart, more coarse particles if it stays together, more fines	coarse or fine:
Compressibility	possibilities	result
 2. crumbling use 425 micron sieve mix into plastic state	both sizes break easily; less clay, low dry strength only small size breaks; medium clay, dry strength is medium neither size breaks; more clay, high dry strength	dry strength:
 3. biscuit use 425 micron sieve mix into plastic state	cookie pulverizes easily, simply reduced to powder (low) not difficult to break, crushed with little effort (medium) difficult to break, with audible snap (high)	dry strength:
Plasticity	possibilities	result
 4. consistency use 425 micron sieve mix into plastic state	weak and fragile thread, breaks and crumbles (coarse) medium-strength thread, can be remodeled (more fines) tough and hard thread, does not crack or crumble (more clay)	thread:
Cohesion	possibilities	result
 5. cigar use 425 micron sieve mix into plastic state	less than 5 cm; more fine sand and silt (low) between 5 and 15 cm; the soil has good consistency (med.) longer than 15 cm; (too) much clay (high)	cohesion:
 6. ribbon use 425 micron sieve mix into plastic state	no ribbon can be made, very little clay (low) between 5 to 25 cm; low to medium amount of clay 25 cm or more; (too) much clay (high)	cohesion:
 7. wet tapping use 425 micron sieve make cohesive ball	rapid reaction: 5 to 10 taps; fine sands and coarse silt slow reaction: 20 to 30 taps; some clay no reaction: much clay	reaction:
Particle Size Distribution	possibilities	result
 8. jar shake use jar with flat bottom	approximate percentages of the particles	% gravel: % sand: % silt: % clay:
 9. wet sieving use 75 micron sieve keep running water	accurate percentage of coarse versus fine particles weight before: weight after:	% coarse: % fine:

note: the soil analyzed is just a small sample. However, the composition and characteristics of a soil may vary greatly, even when found nearby or at the same location. It is therefore recommended to take at least 3 representative samples per site. Then, after modification and stabilization of the soil, it is recommended to make and examine some test blocks, in order to find out the actual behaviour of the finished product.

Overall Findings	structure:	compressibility:	plasticity:
	cohesion:	particle size distribution:	
Classification of Sample	e.g. sandy silt or clayey gravel e.g. suitable or unsuitable		
Soil Modification	earth technique proposed: modification / stabilization of soil:		